

Digital Optical Technologies II, Munich, June 25, 2019

Systematic design approach for lightguide devices for XR applications

C. Hellmann^{***}, S. Steiner^{**}, R. Knoth^{**}, S. Zhang^{**}, F. Wyrowski^{*}

^{*}University of Jena, ^{**} LightTrans GmbH, ^{***}Wyrowski Photonics

Lightguide Modeling and Design

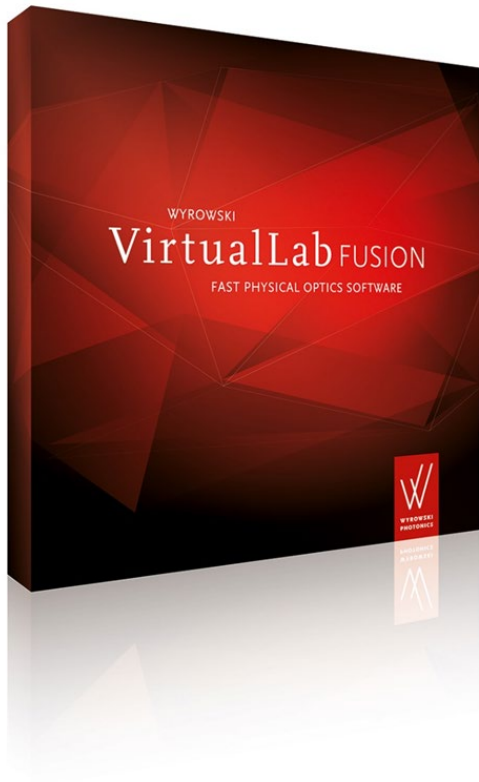
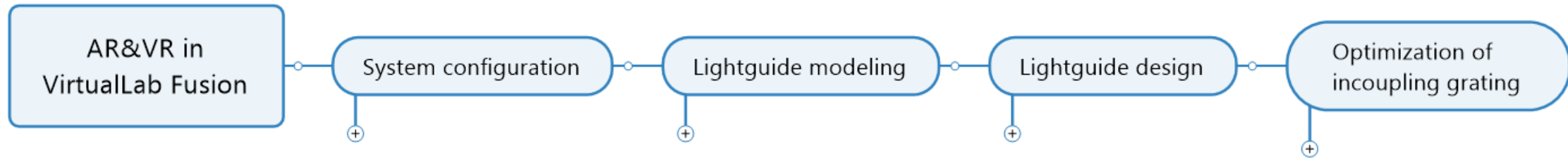

New features coming in Summer (July) and Autumn Releases

Lightguide Modeling and Design

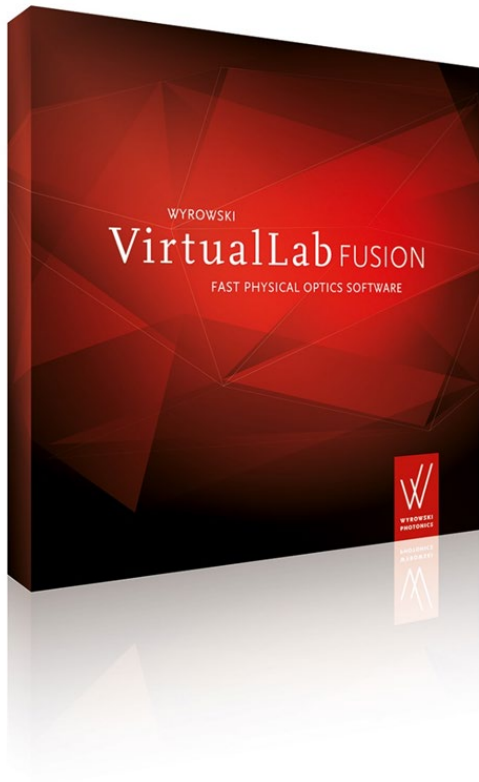
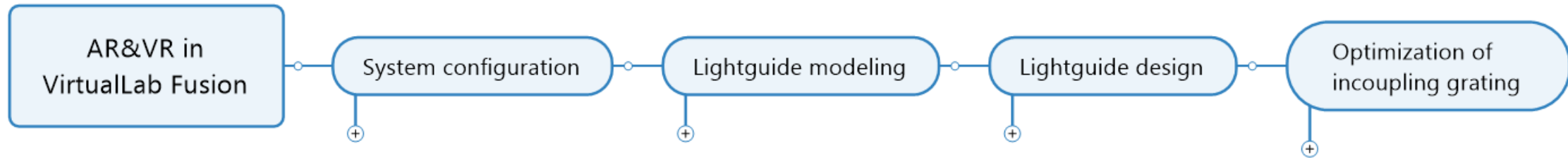

Lightguide Modeling and Design

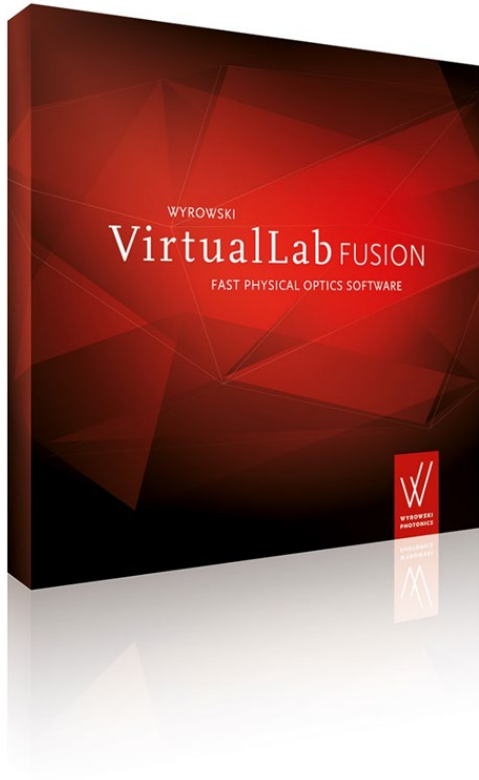
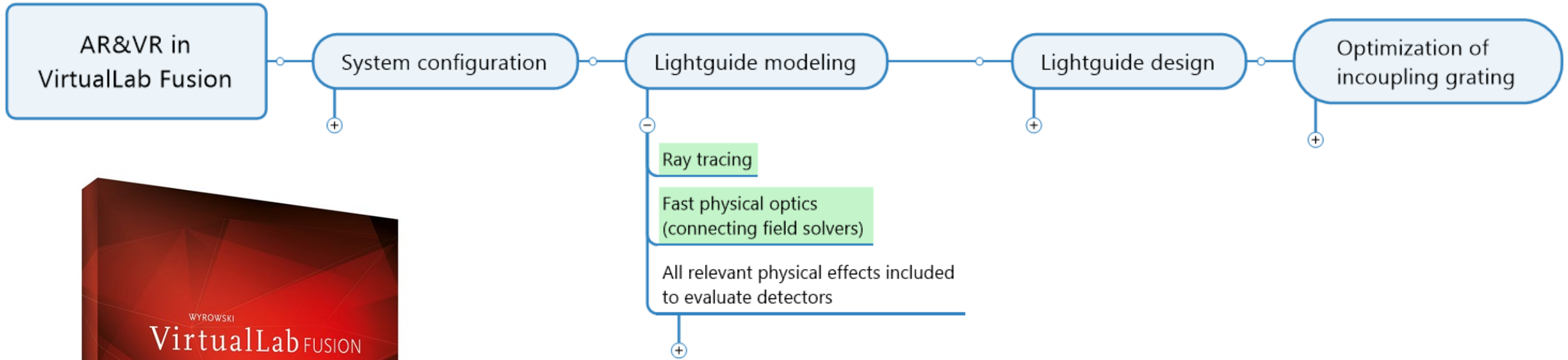

Lightguide Modeling and Design

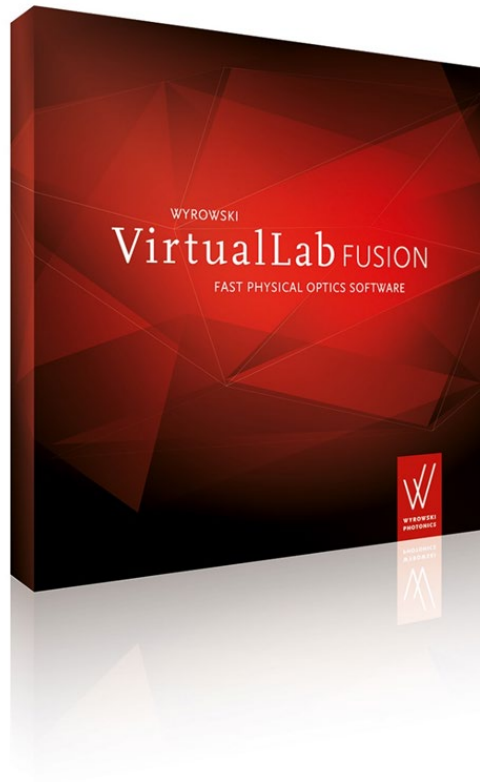
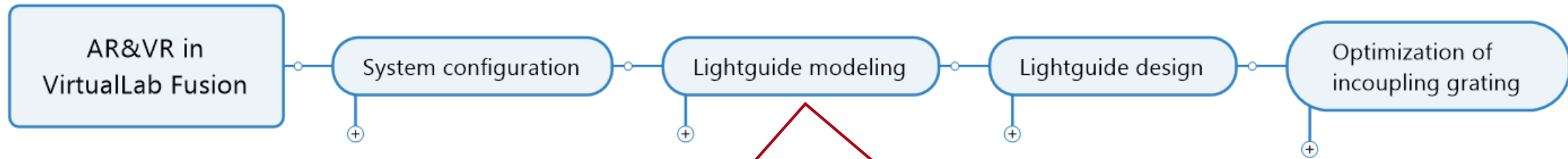

11:00: **Physical-optics analysis of lightguides for augmented and mixed reality glasses**, Christian Hellmann, Wyrowski Photonics UG (Germany); Stefan Steiner, Roberto Knoth, Site Zhang, LightTrans International UG (Germany); Frank Wyrowski, Friedrich-Schiller-Univ. Jena (Germany) [11062-16]

Lightguide Modeling and Design

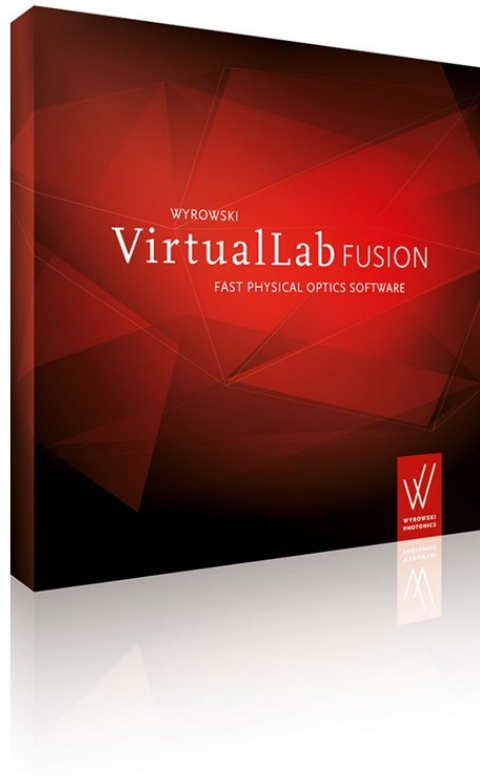
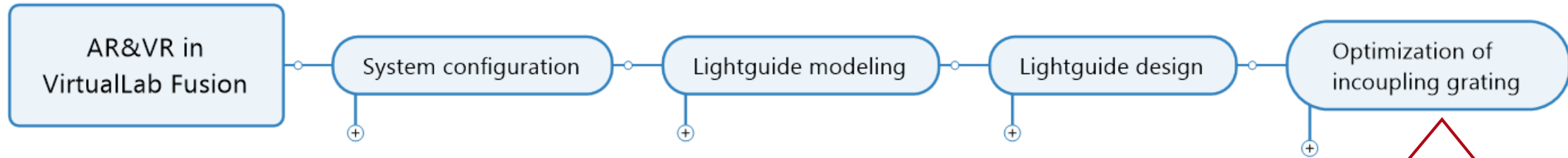

11:40: Physical-optical analysis of lightguide coupling setup and systematic design strategy, Roberto Knoth, Stefan Steiner, Site Zhang, LightTrans International UG (Germany); Christian Hellmann, Wyrowski Photonics UG (Germany); Frank Wyrowski, Friedrich-Schiller-Univ. Jena (Germany) [11062-18]

Lightguide Modeling and Design

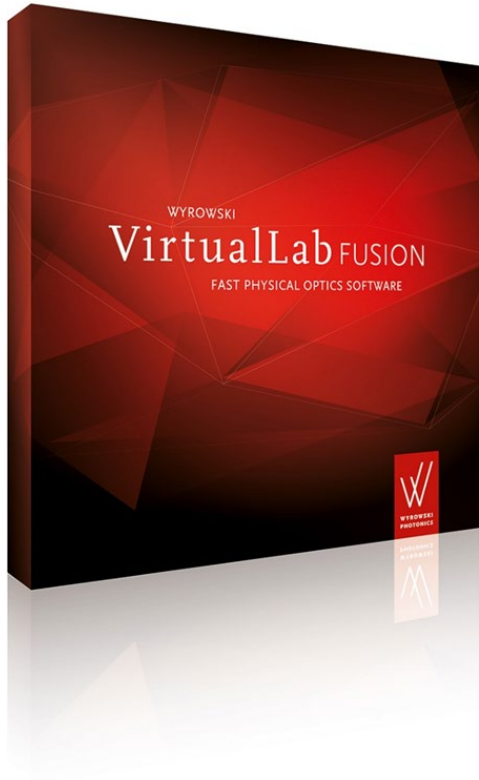
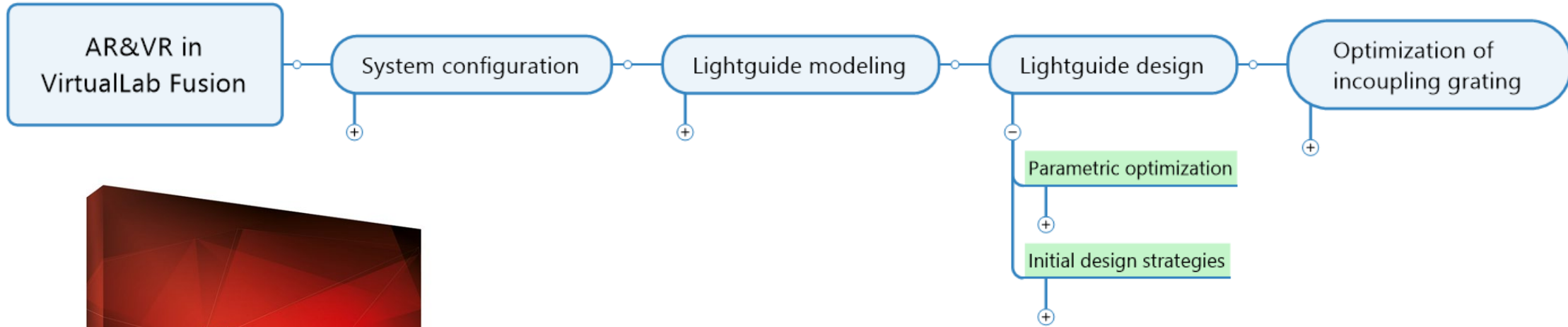

Selection of design criteria?

Lightguide Concept: In/Out Coupling

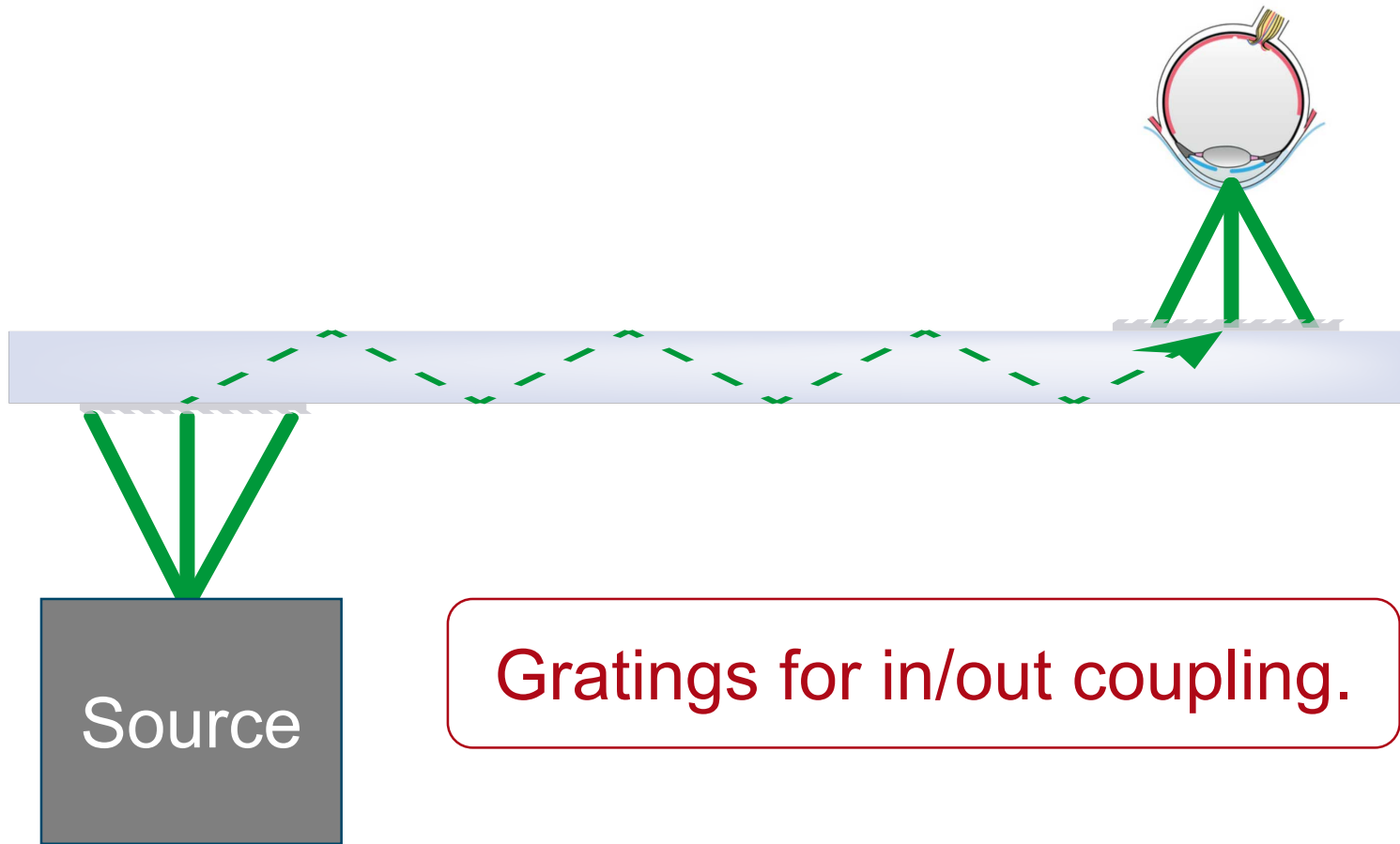

Lightguide Concept: Fundamental Design Criteria

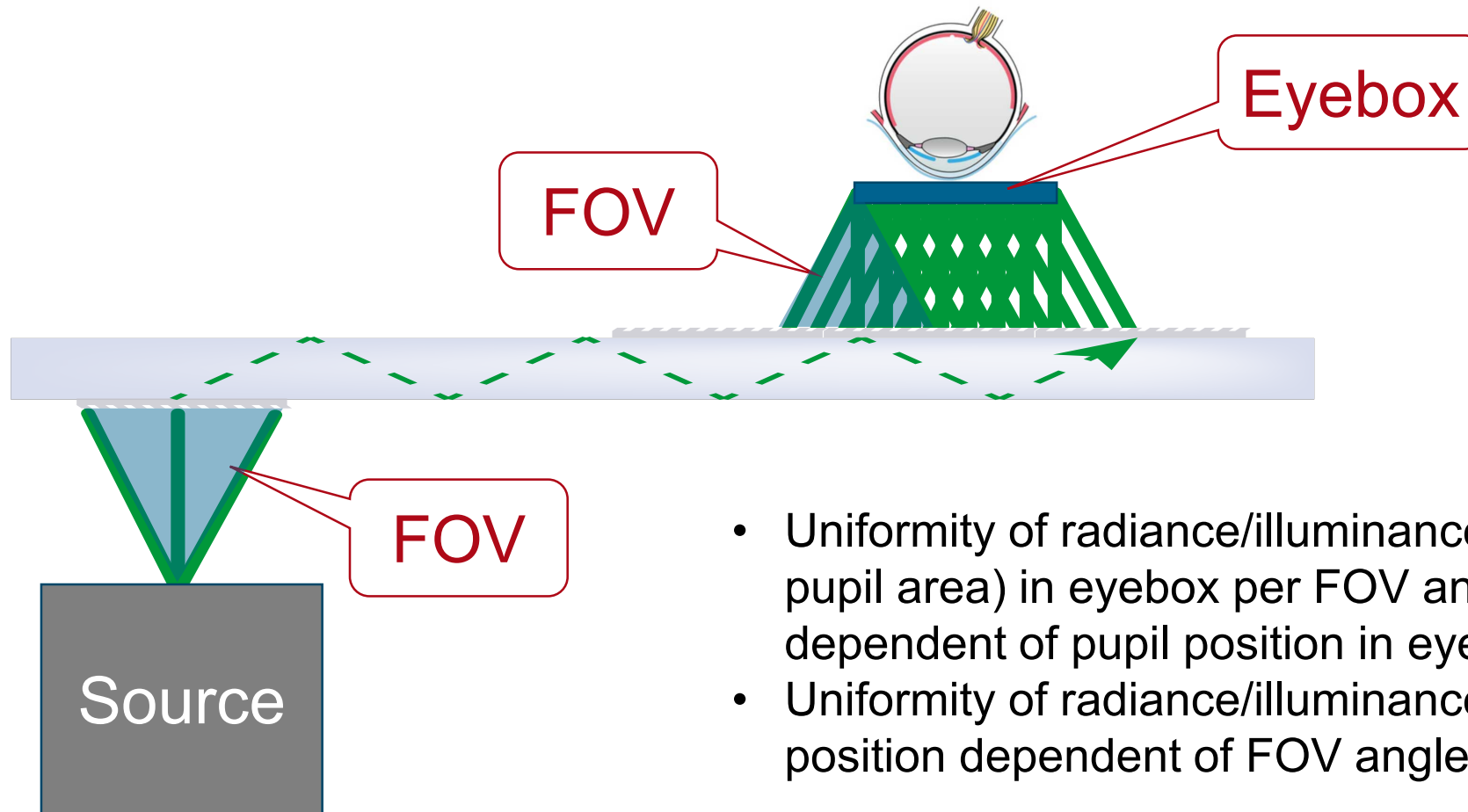

- Uniformity of radiance/illuminance (per pupil area) in eyebox per FOV angle/mode dependent of pupil position in eyebox.
- Uniformity of radiance/illuminance per pupil position dependent of FOV angles.

Lightguide Concept: Fundamental Design Criteria

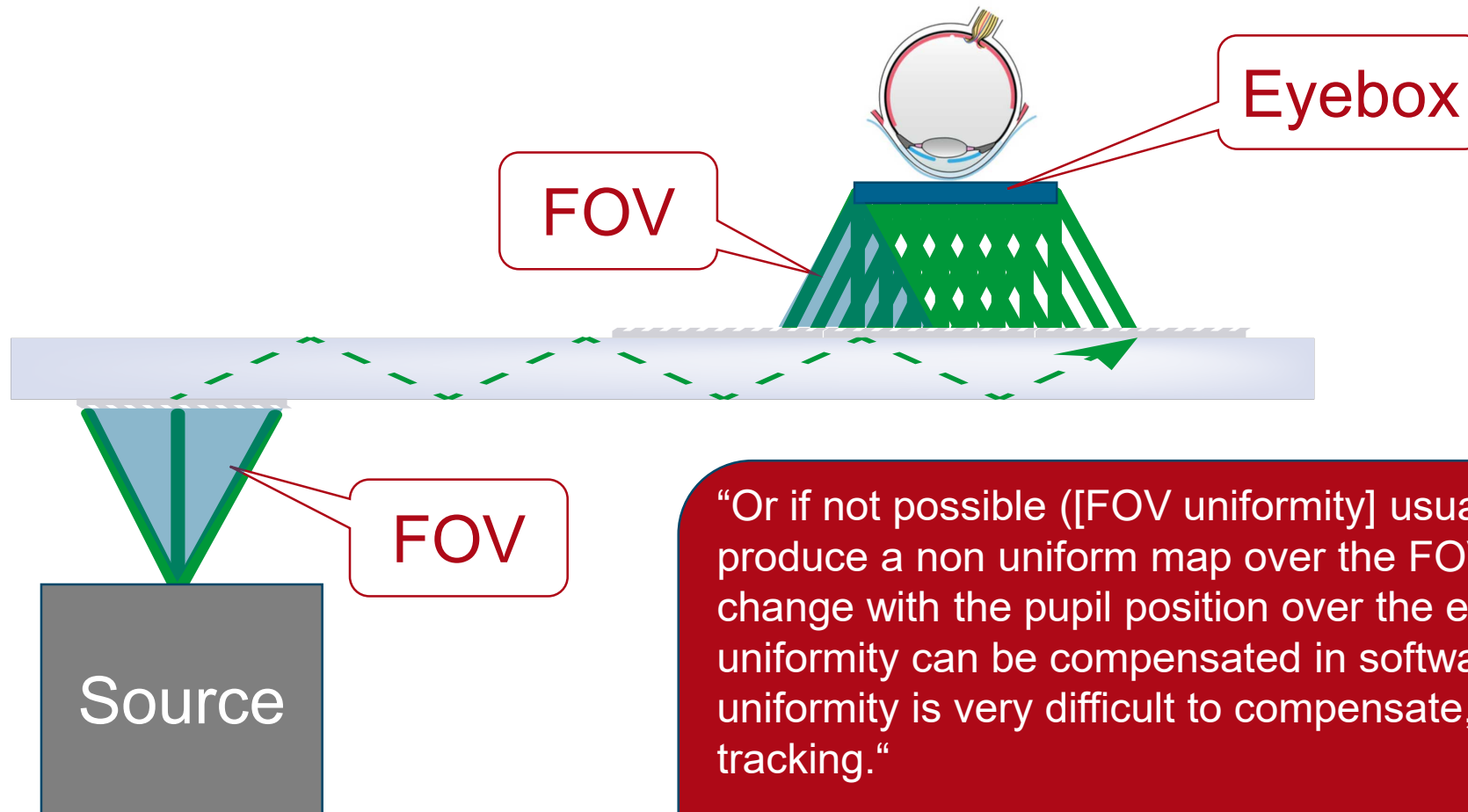

“Or if not possible ([FOV uniformity] usually the case), produce a non uniform map over the FOV that does not change with the pupil position over the eyebow. FOV non uniformity can be compensated in software, eye box non uniformity is very difficult to compensate, even with pupil tracking.”

Bernard Kress, Microsoft (private communication)

Lightguide Concept: Fundamental Design Criteria

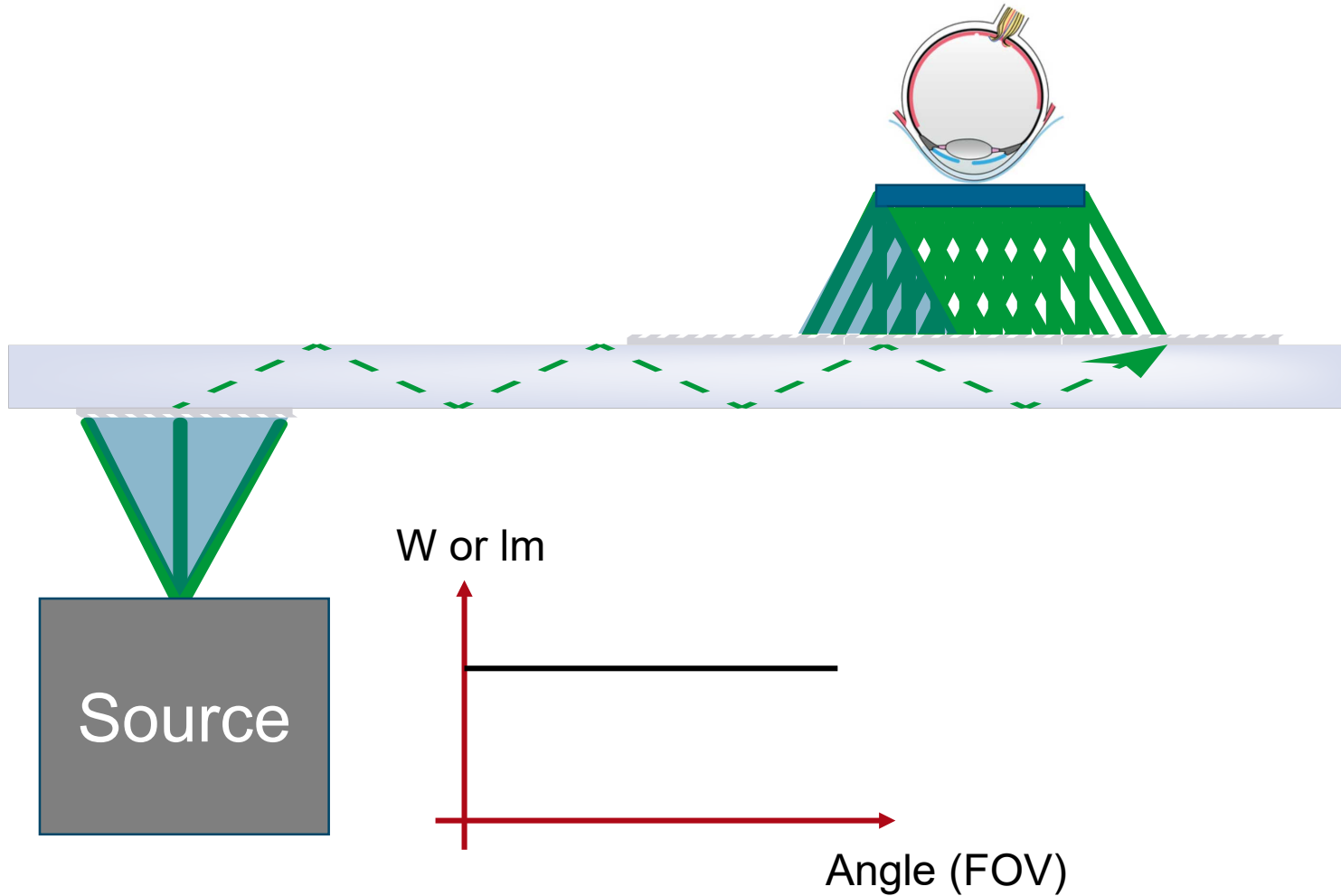

Lightguide Concept: Fundamental Design Criteria

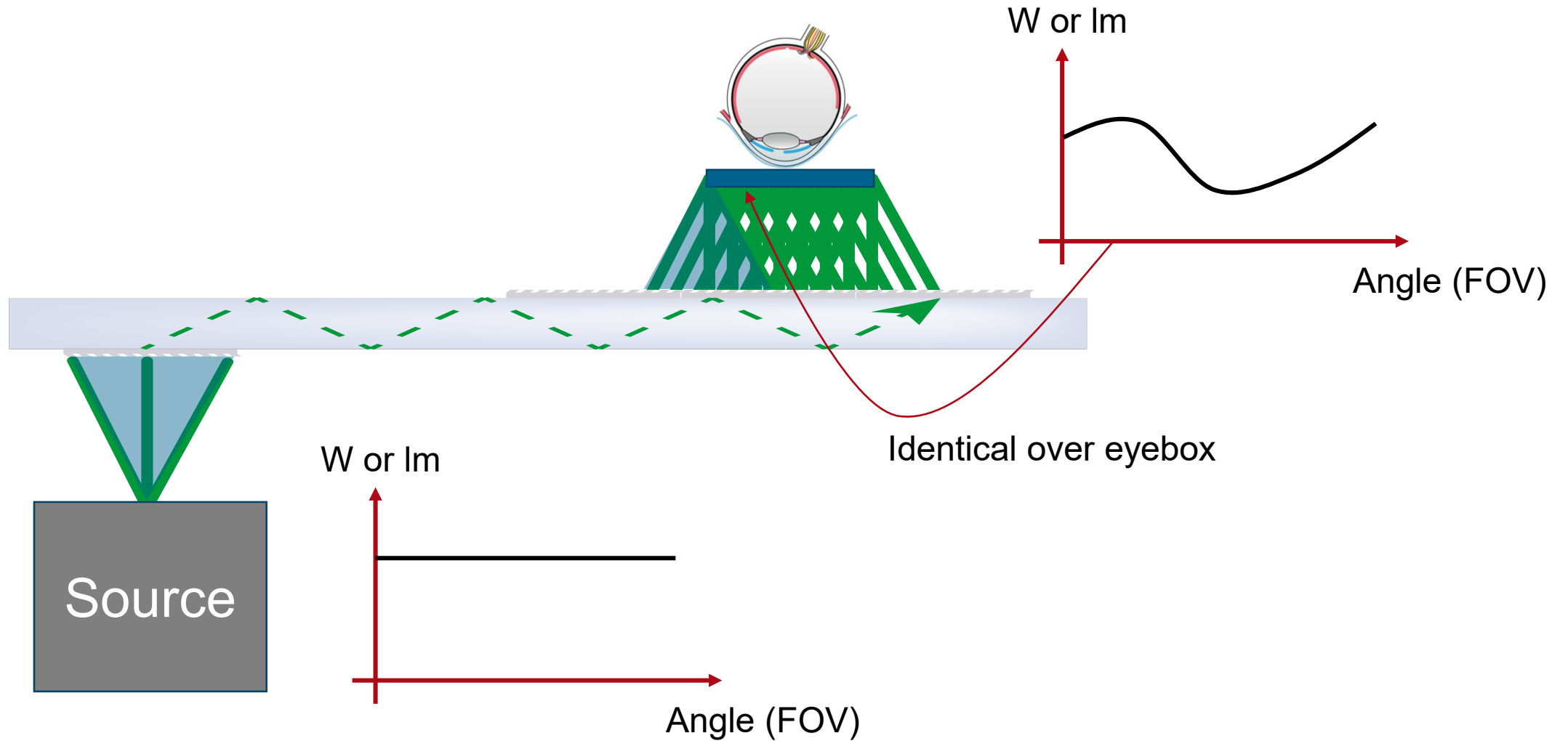

Lightguide Concept: Fundamental Design Criteria

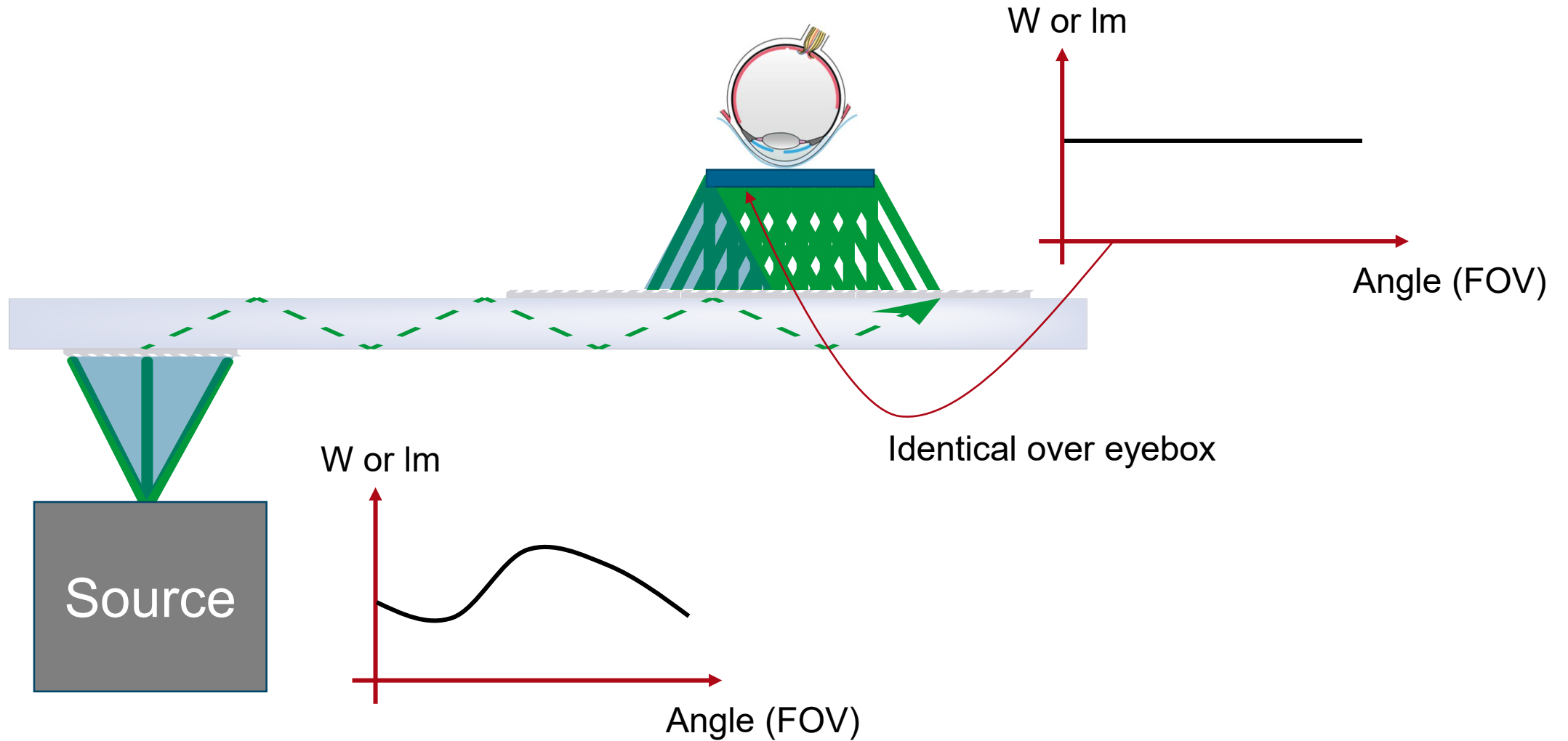

Lightguide Concept: Fundamental Design Criteria

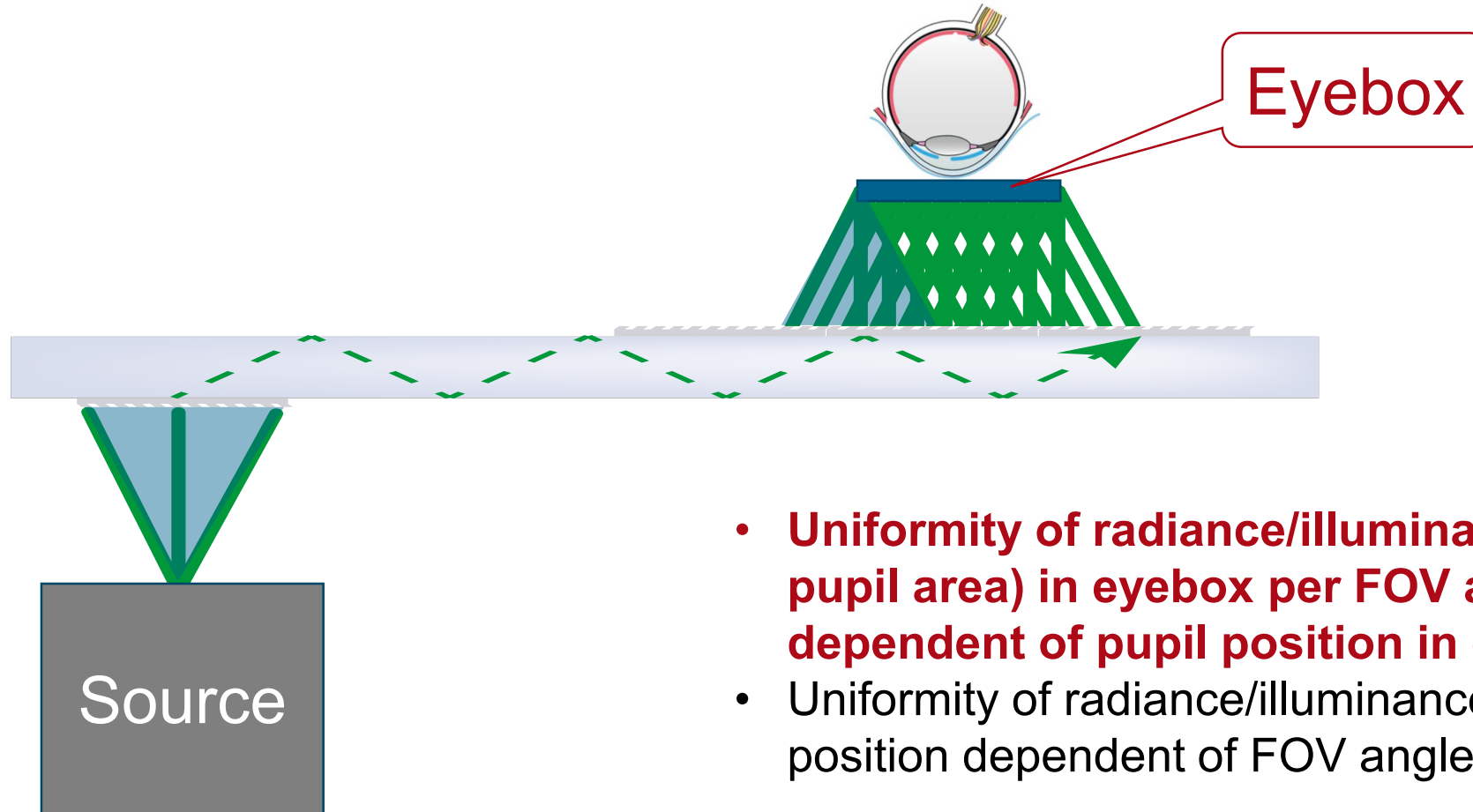

- **Uniformity of radiance/illuminance (per pupil area) in eyebox per FOV angle/mode dependent of pupil position in eyebox.**
- Uniformity of radiance/illuminance per pupil position dependent of FOV angles.

Lightguide Concept: Modeling Task

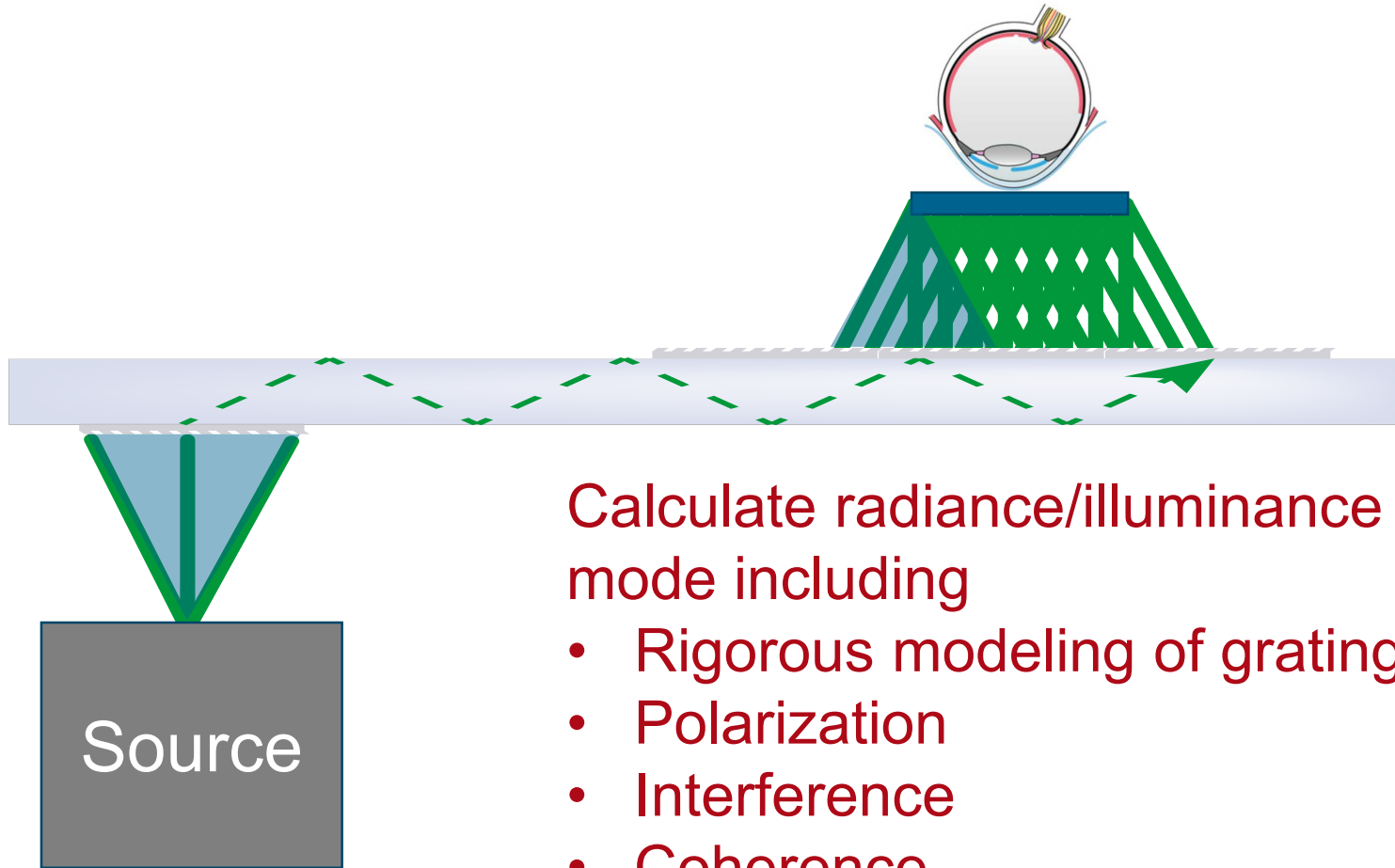

Calculate radiance/illuminance per FOV mode including

- Rigorous modeling of gratings
- Polarization
- Interference
- Coherence

Parametric Optimization of Lightguide Parameters

Parametric
optimization

Lightguide Modeling and Design

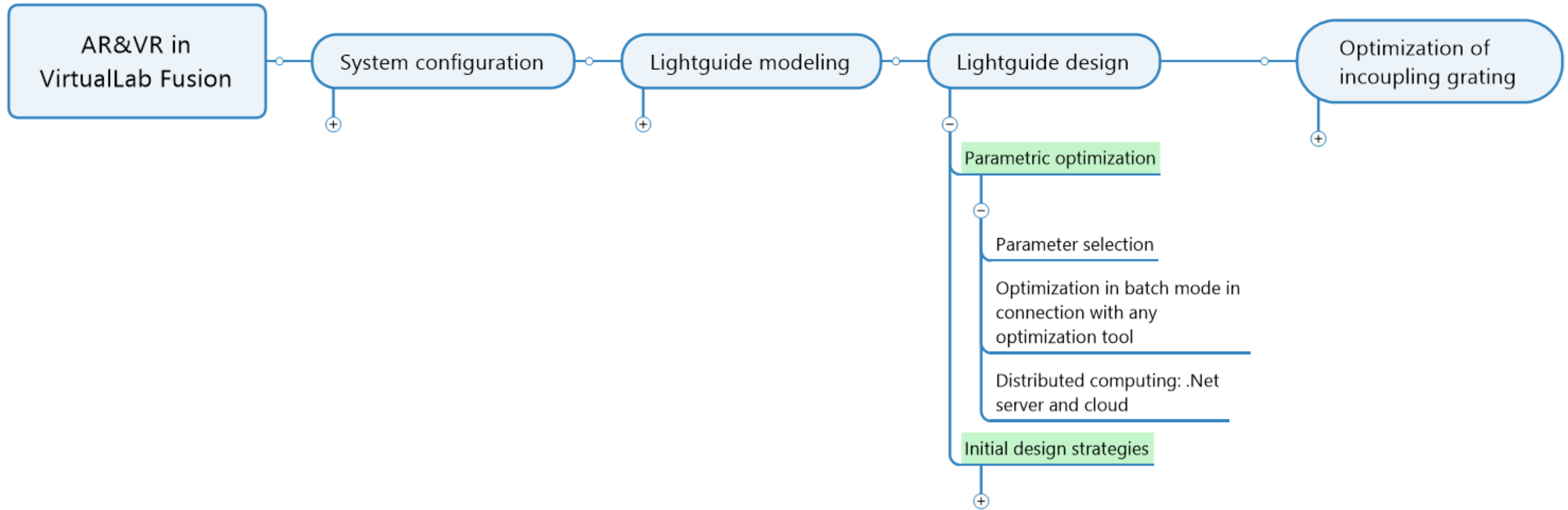

Cross Platform Simulation/Optimization - Python

PYTHON

- interactive access to batch mode files
- external mathematical functions and tools

Batch mode files

- execution of simulations
- optical parameters and simulation result storage

VirtualLab Fusion

- optical setup definition
- kernel simulation engine

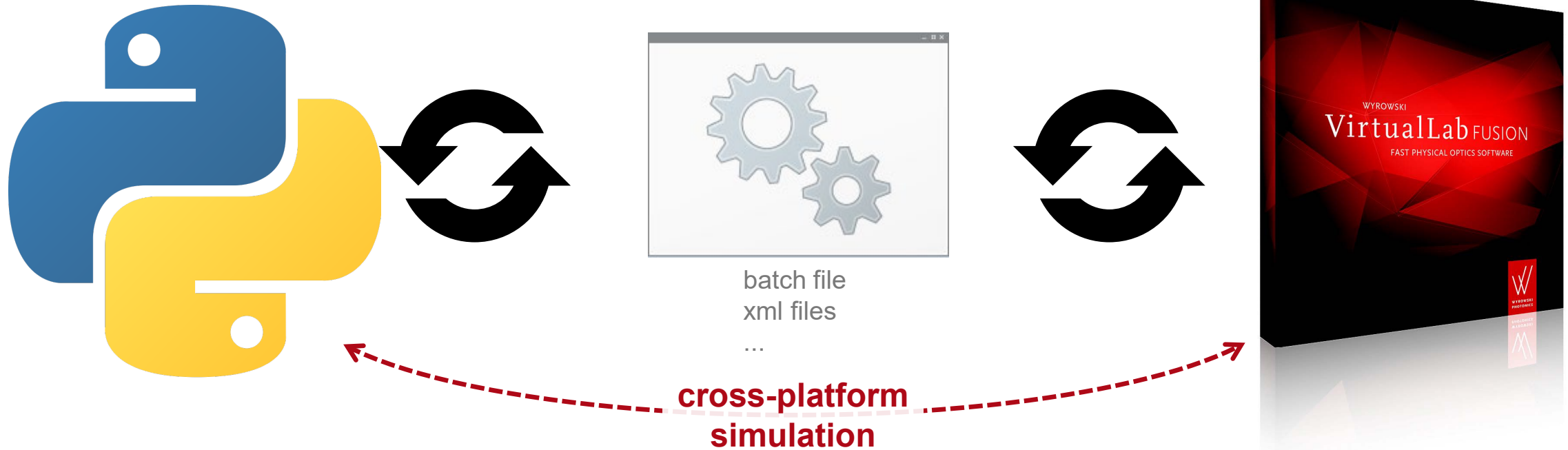

Cross Platform Simulation/Optimization - MATLAB

MATLAB

- interactive access to batch mode files
- external mathematical functions and tools

Batch mode files

- execution of simulations
- optical parameters and simulation result storage

VirtualLab Fusion

- optical setup definition
- kernel simulation engine

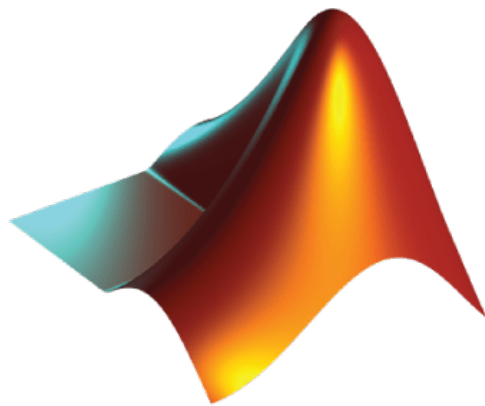

MATLAB

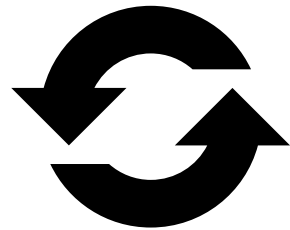

batch file
xml files
...

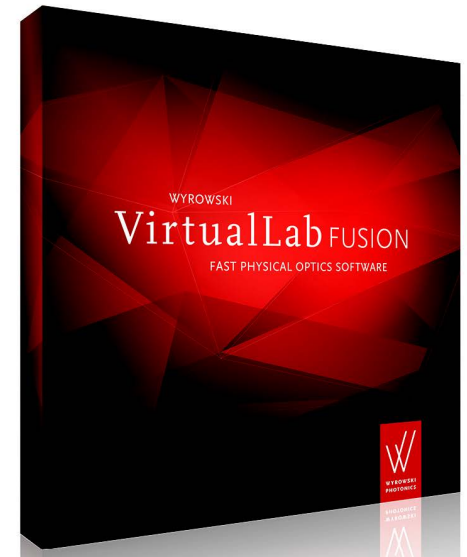
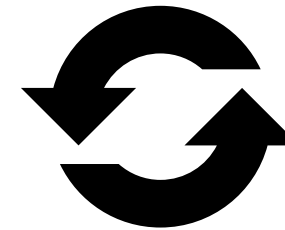

**cross-platform
simulation**

Cross Platform Simulation/Optimization - optiSLang

optiSLang

- interactive access to batch mode files
- internal mathematical functions and tools

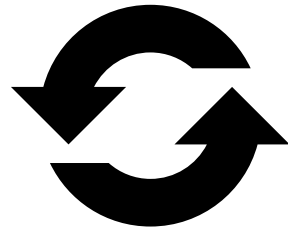

Batch mode files

- execution of simulations
- optical parameters and simulation result storage



batch file
xml files
...

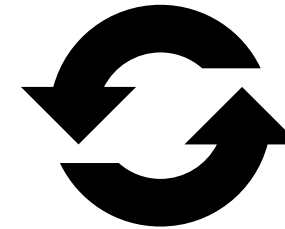

VirtualLab Fusion

- optical setup definition
- kernel simulation engine

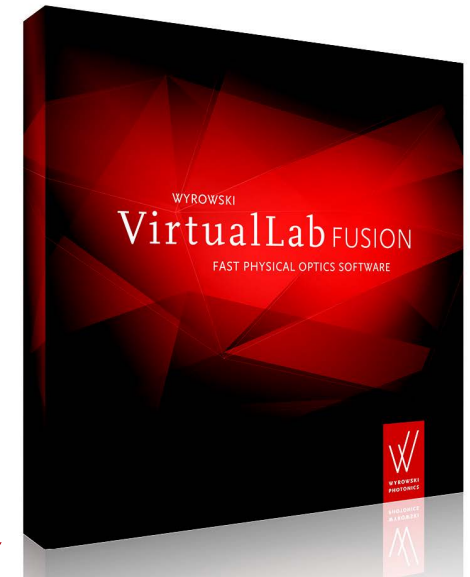

cross-platform
simulation

Cross Platform Simulation/Optimization - optiSLang

11:40: Physical-optical analysis of lightguide coupling setup and systematic design strategy, Roberto Knoth, Stefan Steiner, Site Zhang, LightTrans International UG (Germany); Christian Hellmann, Wyrowski Photonics UG (Germany); Frank Wyrowski, Friedrich-Schiller-Univ. Jena (Germany) [11062-18]

ulations
s and
storage

VirtualLab Fusion

- optical setup definition
- kernel simulation engine

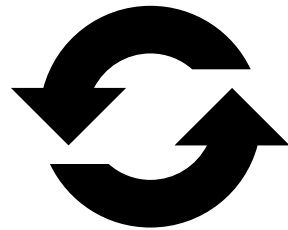

batch file
xml files
...

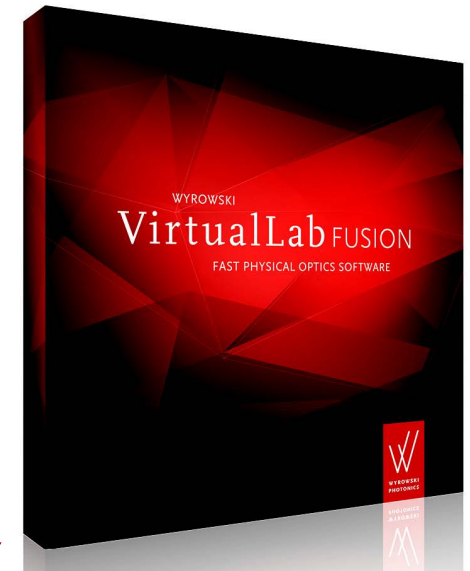
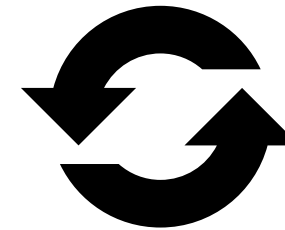

Cloud Computing

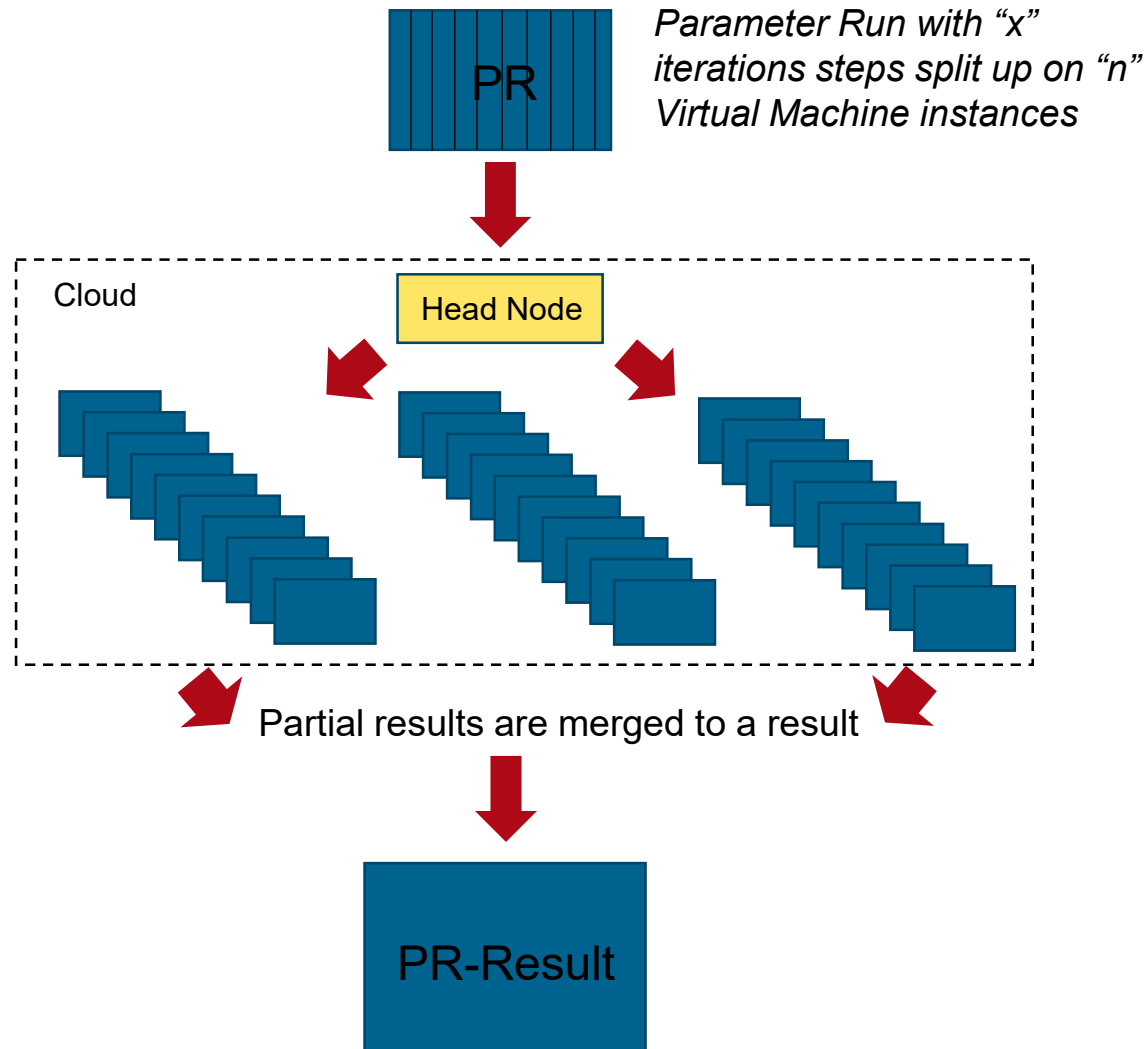

VirtualLab supports cloud computing on Azure cloud:

- Cluster with e.g. 8 or more nodes
- Windows Machines with e.g. Windows Server 2012 R2 OS
- Software: HPC Pack 2012 (Microsoft tool) (High Performance Computing)

The usage of cloud computing enables a speed up of the simulation, which can be scaled by the size of the cluster in use.

Parametric Optimization by VirtualLab & External Tools

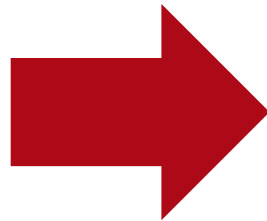
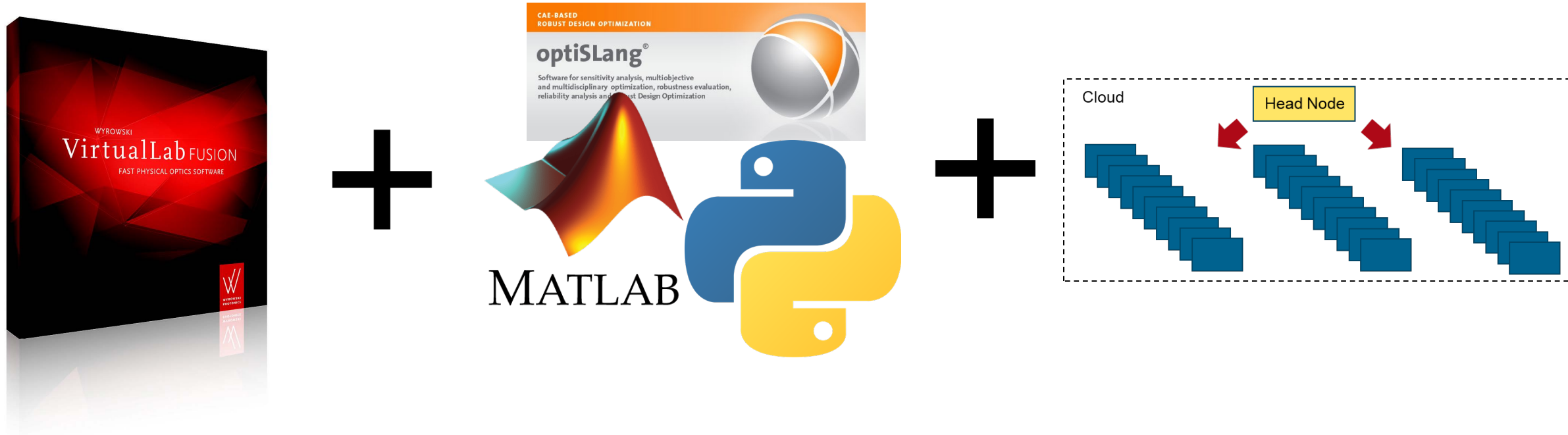

Provides full flexibility by a powerful combination of tools to find the best solution for your lightguide architecture

Parametric Optimization of Lightguide Parameters

Parametric
optimization

Parametric Optimization and Initial Design

Initial design, e.g.

- Inverse approaches
- Functional design



Parametric optimization

Lightguide Modeling and Design

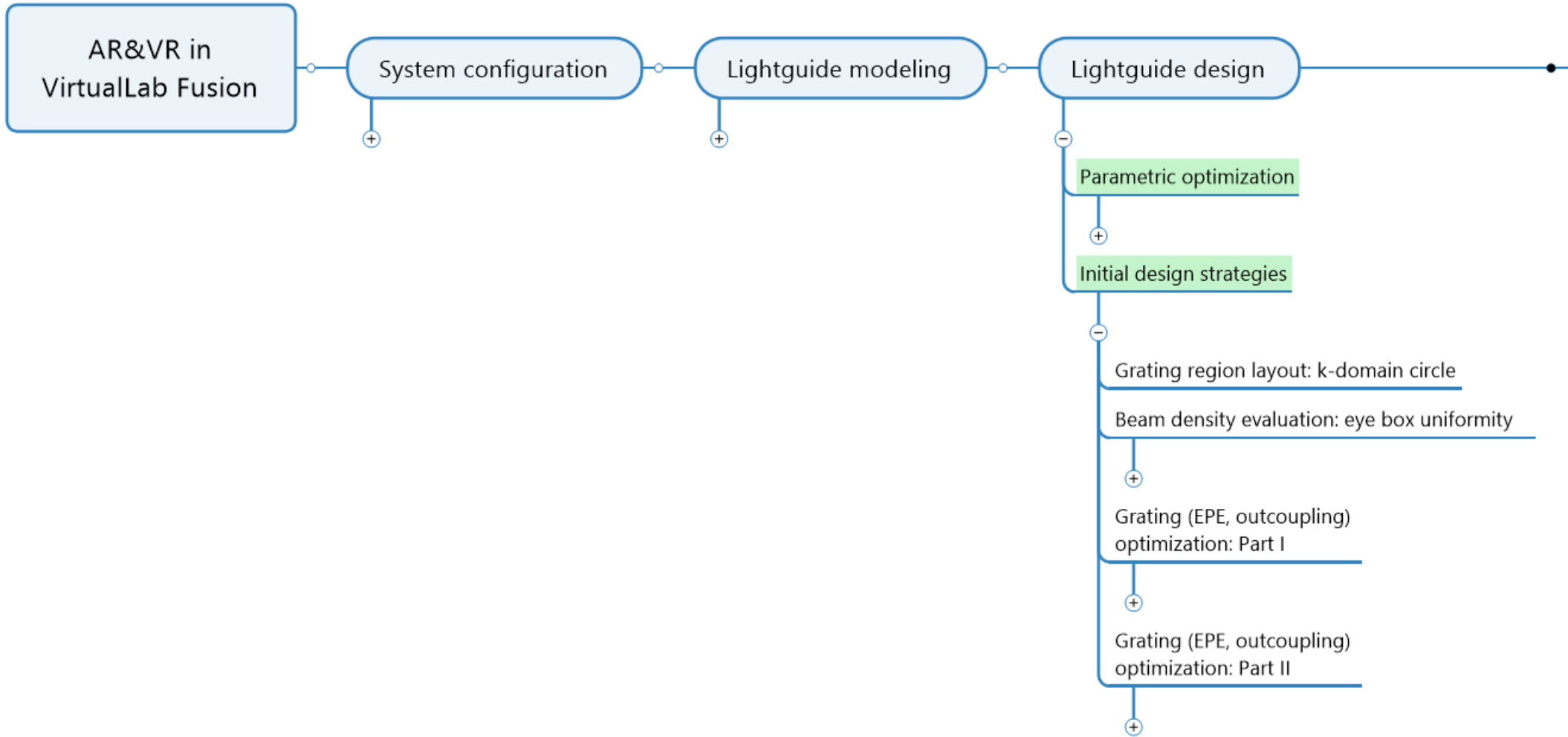

Lightguide Modeling and Design

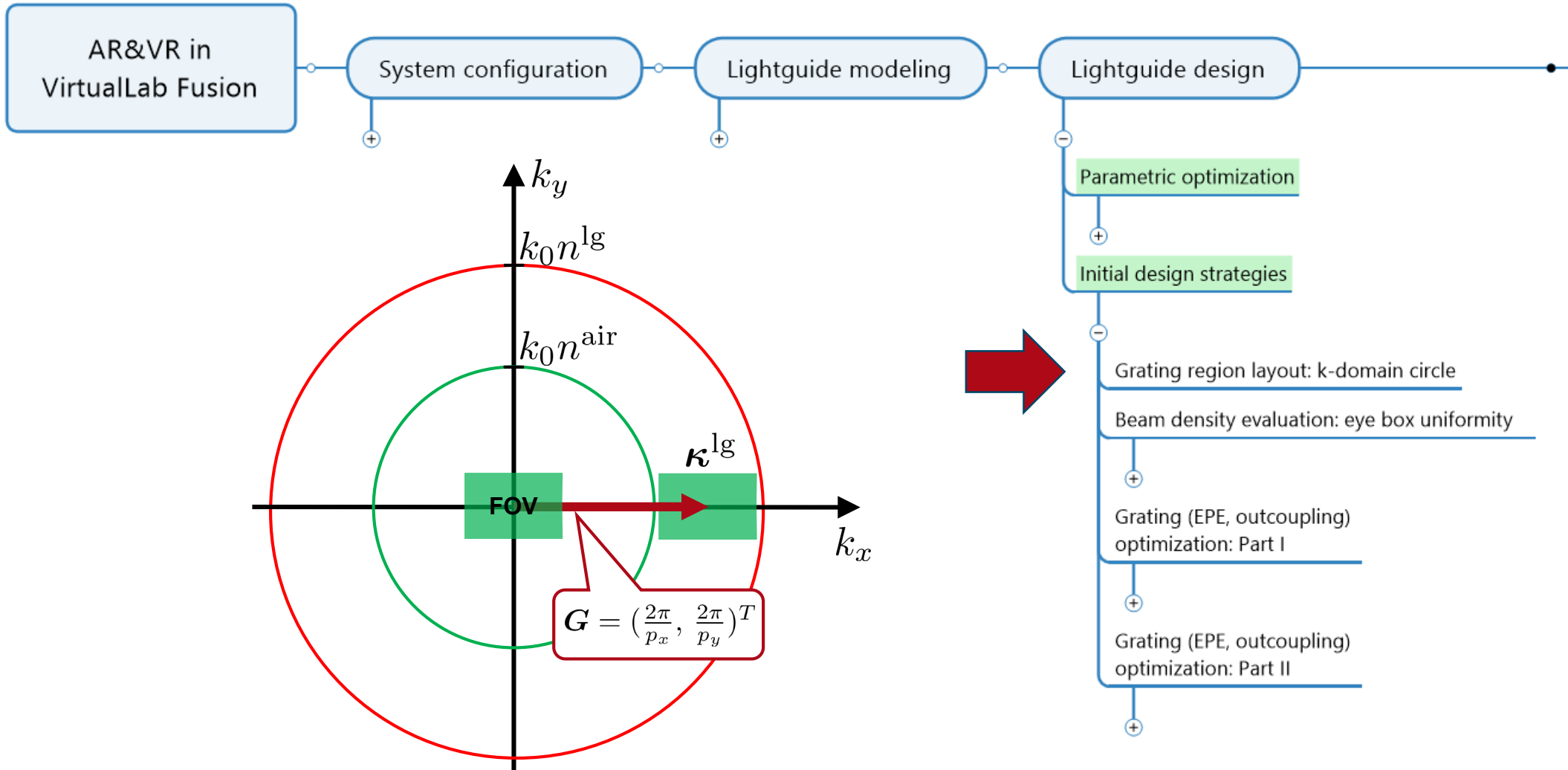

Lightguide Modeling and Design

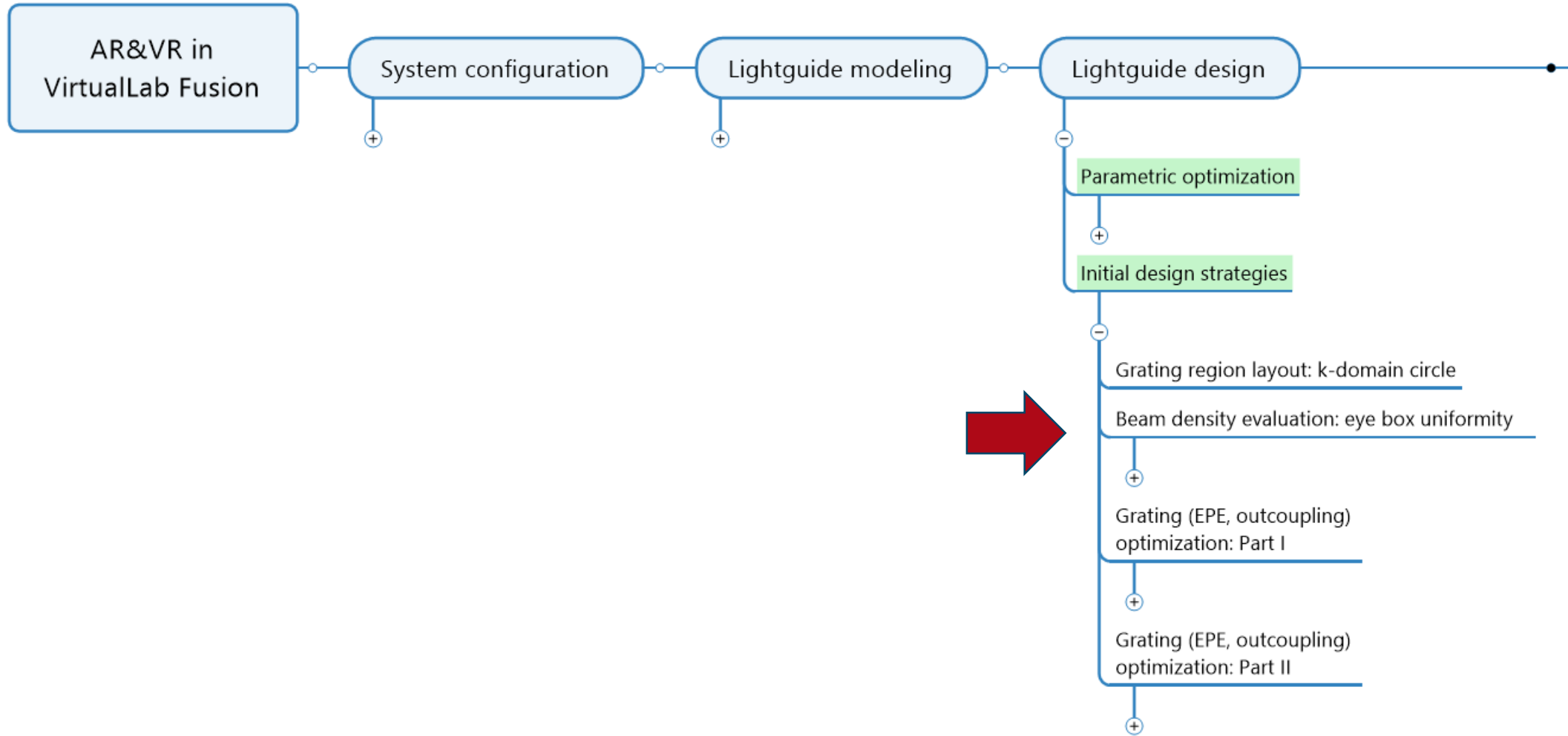

Eyebox Uniformity vs. Beam Density

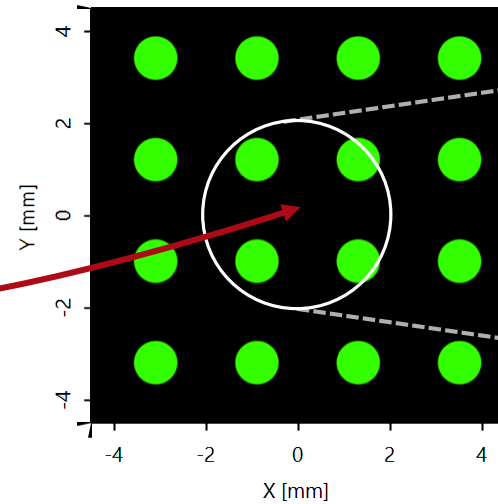
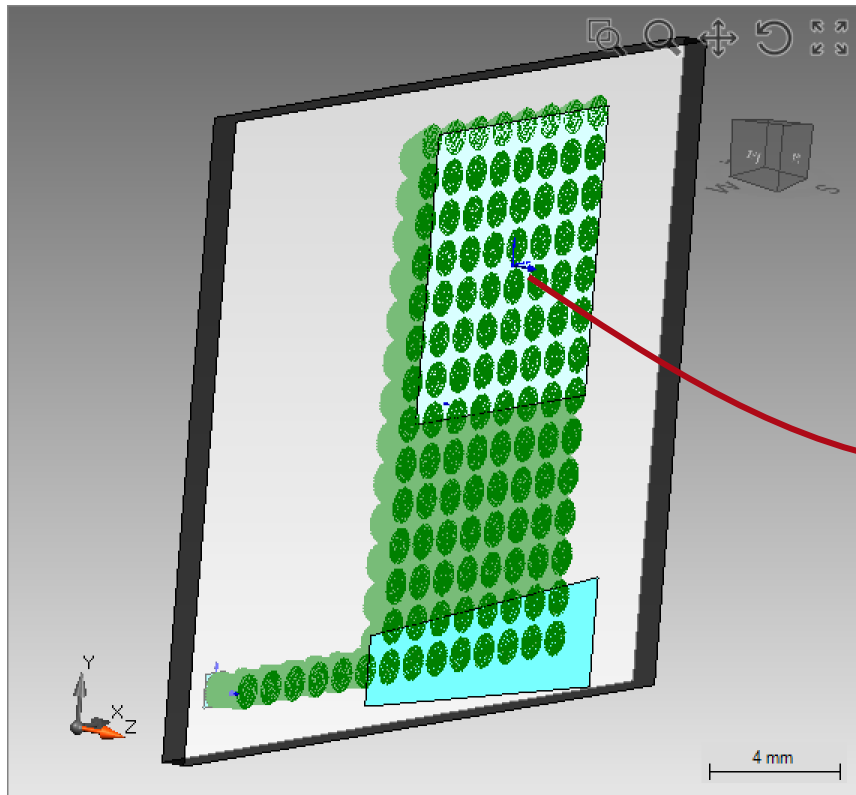

outcoupled light

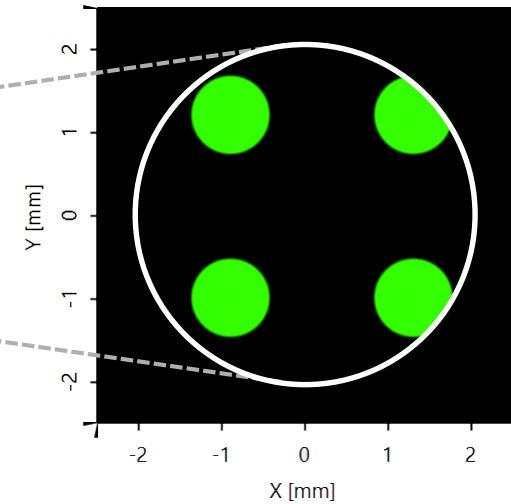

behind eye pupil

Eyebox Uniformity vs. Beam Density

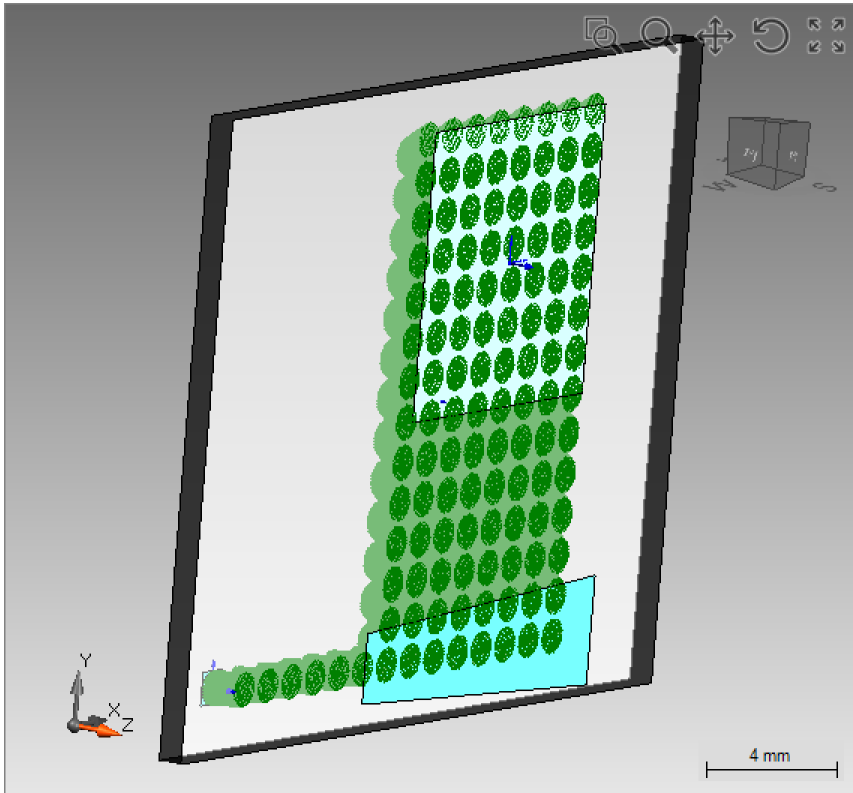

- Per eye position (x, y) in eyebox the flux into the eye per FOV angle (θ_x, θ_y) is calculated, which represents the radiance L_e .
- The uniformity error $\Omega(\theta_x, \theta_y)$ is defined as the contrast of L_e :

$$\Omega(\theta_x, \theta_y) = \frac{\max_{(x,y)} L_e(\theta_x, \theta_y; x, y) - \min_{(x,y)} L_e(\theta_x, \theta_y; x, y)}{\max_{(x,y)} L_e(\theta_x, \theta_y; x, y) + \min_{(x,y)} L_e(\theta_x, \theta_y; x, y)}$$

Eyebox Uniformity vs. Beam Density

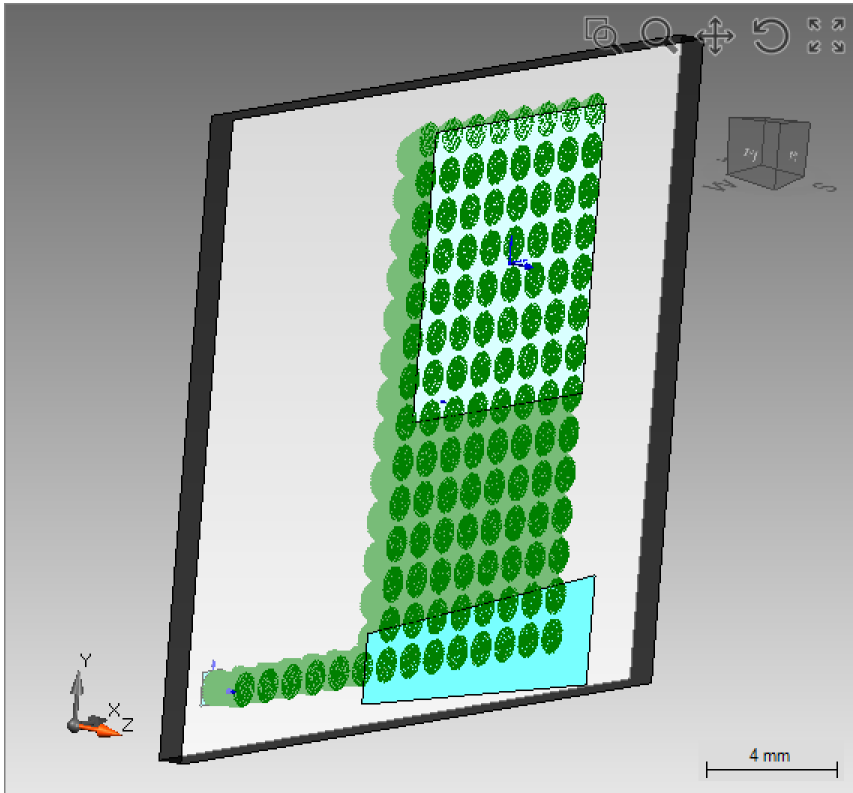

Initial investigation:

- Assume ideal gratings which provide perfectly uniform beams.
- Concentrate on beam density vs.
 - Thickness of lightguide
 - Beam size (light engine)
 - Off-axis angle incoupling

Eyebox Uniformity vs. Beam Density

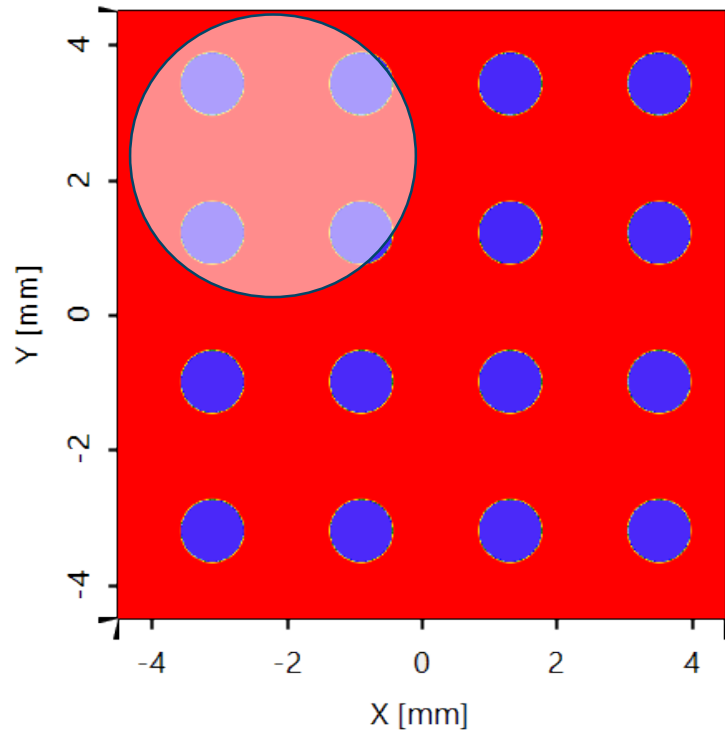

Irradiance in eyebox: FOV (0°, 0°)

Eyebox Uniformity vs. Beam Density

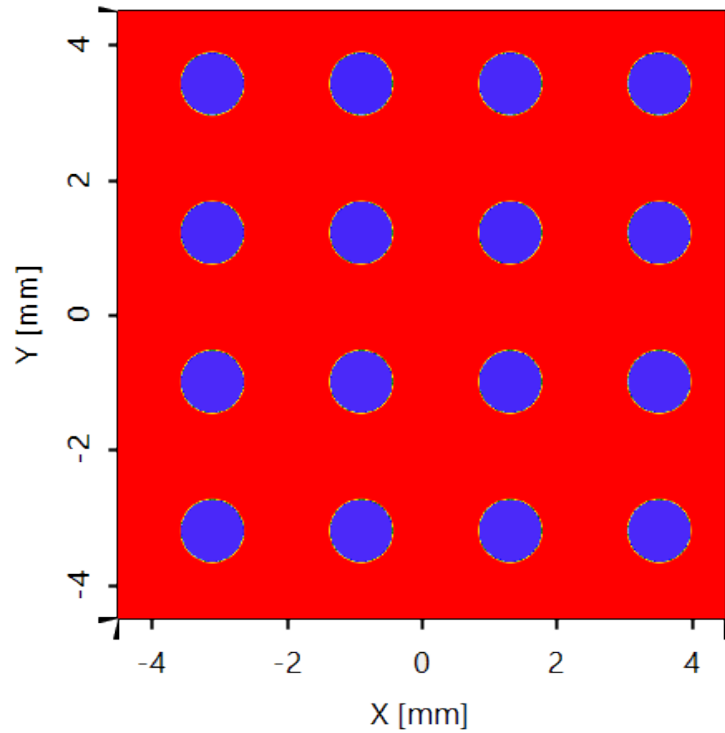

Irradiance in eyebox: FOV (0°, 0°)

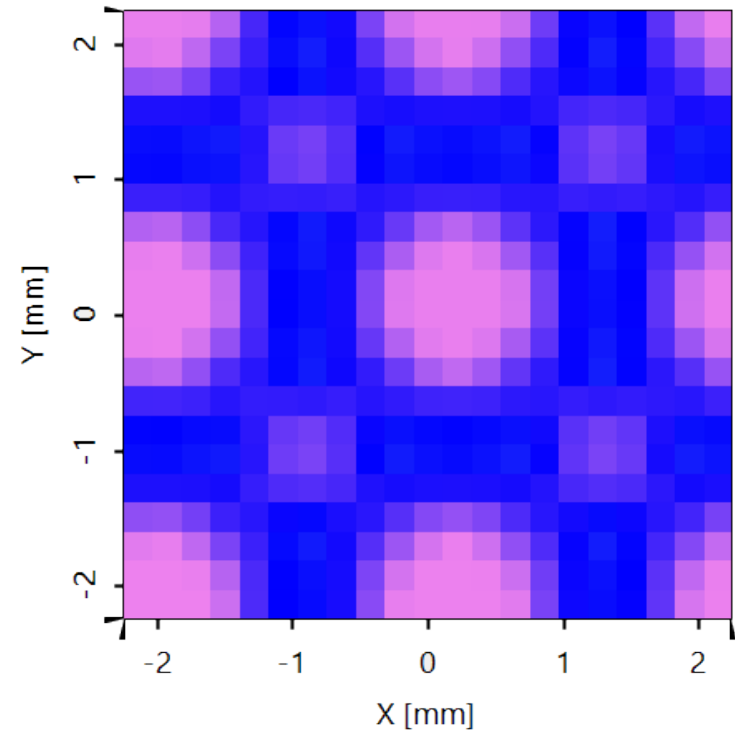

Radiance FOV (0°, 0°)

Uniformity: 10.5%

Eyebox Uniformity vs. Beam Density: Single Wavelength

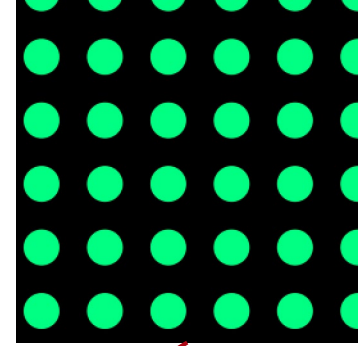
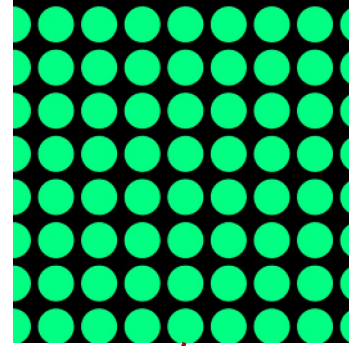
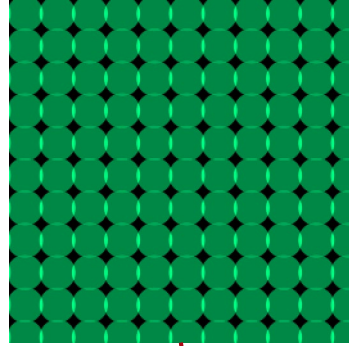
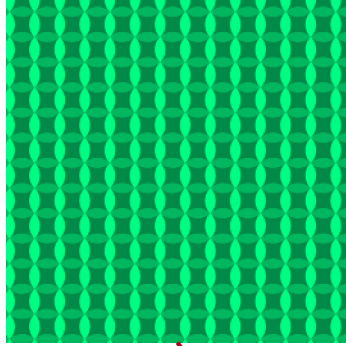

Source

- Plane Wave (0° , 0°)
- Single Wavelength (532nm)

Detector:

- Eye Pupil Diameter - 4.5mm
- Number Eye Positions - 21 x 21

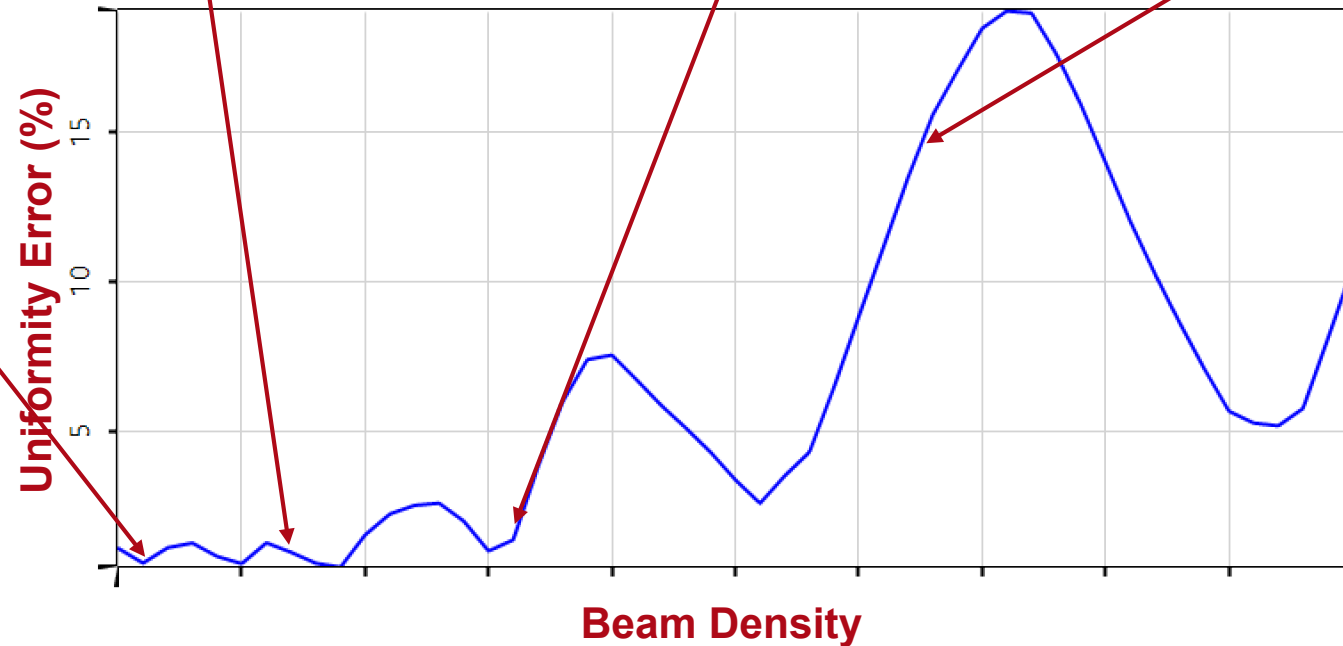

Eyebox Uniformity vs. Beam Density: Single Wavelength

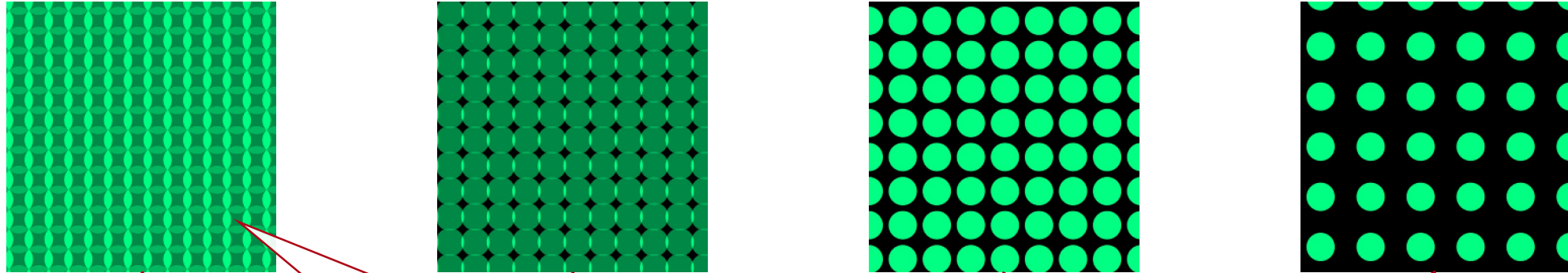

Beams per
FOV/wavelength
are correlated!

Source

- Plane Wave ($0^\circ, 0^\circ$)
- Single Wavelength (532nm)

Detector:

- Eye Pupil Diameter - 4.5mm
- Number Eye Positions - 21 x 21

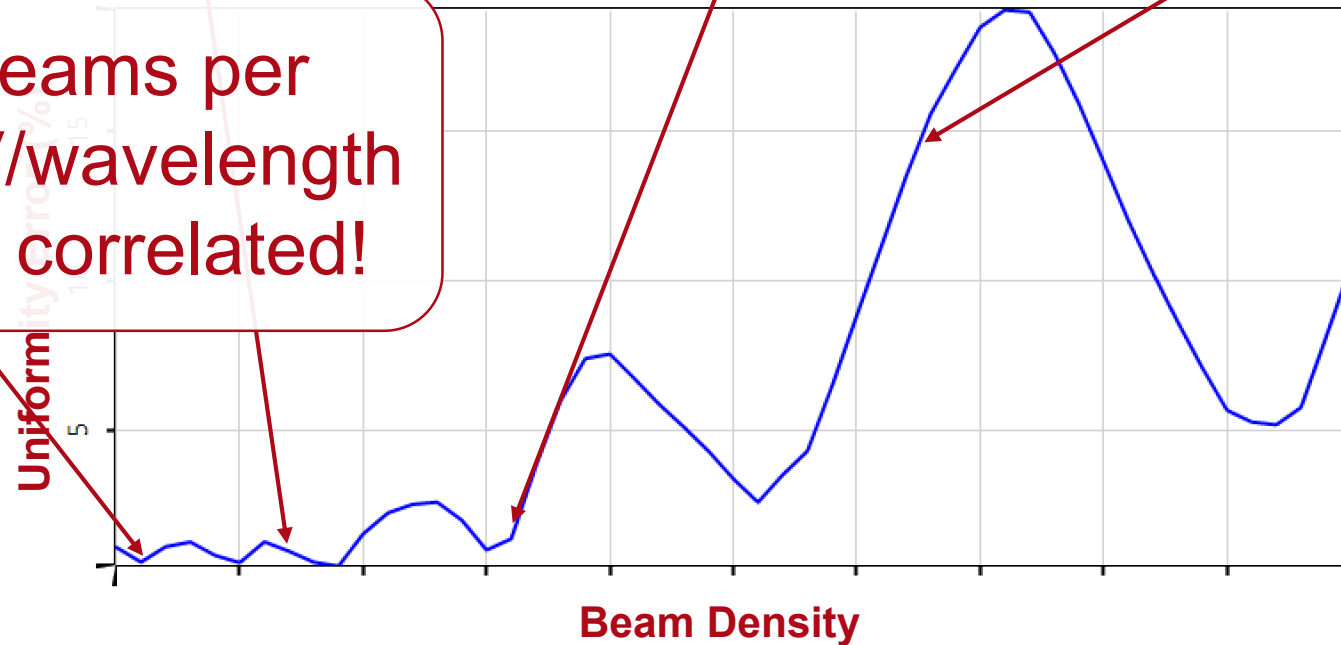

Eyebox Uniformity vs. Beam Density: Bandwidth 1nm

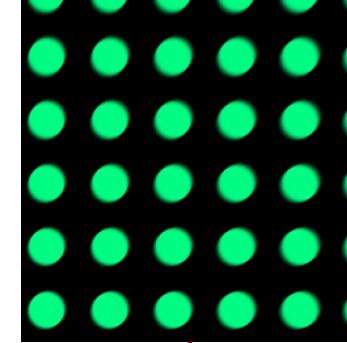
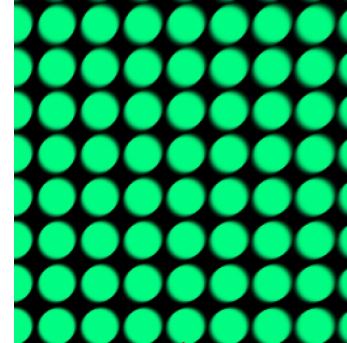
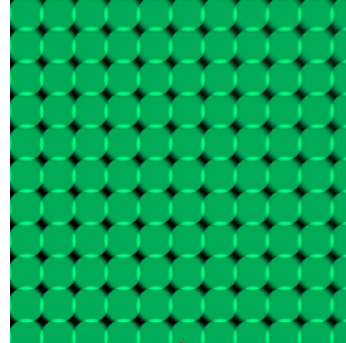
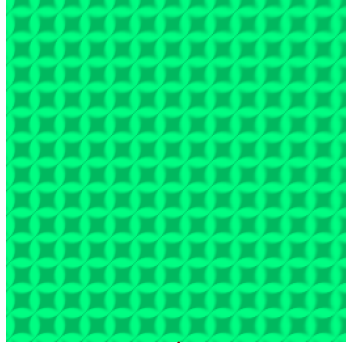

Source

- Plane Wave ($0^\circ, 0^\circ$)
- **Bandwidth – 1nm**

Detector:

- Eye Pupil Diameter - 4.5mm
- Number Eye Positions - 21 x 21

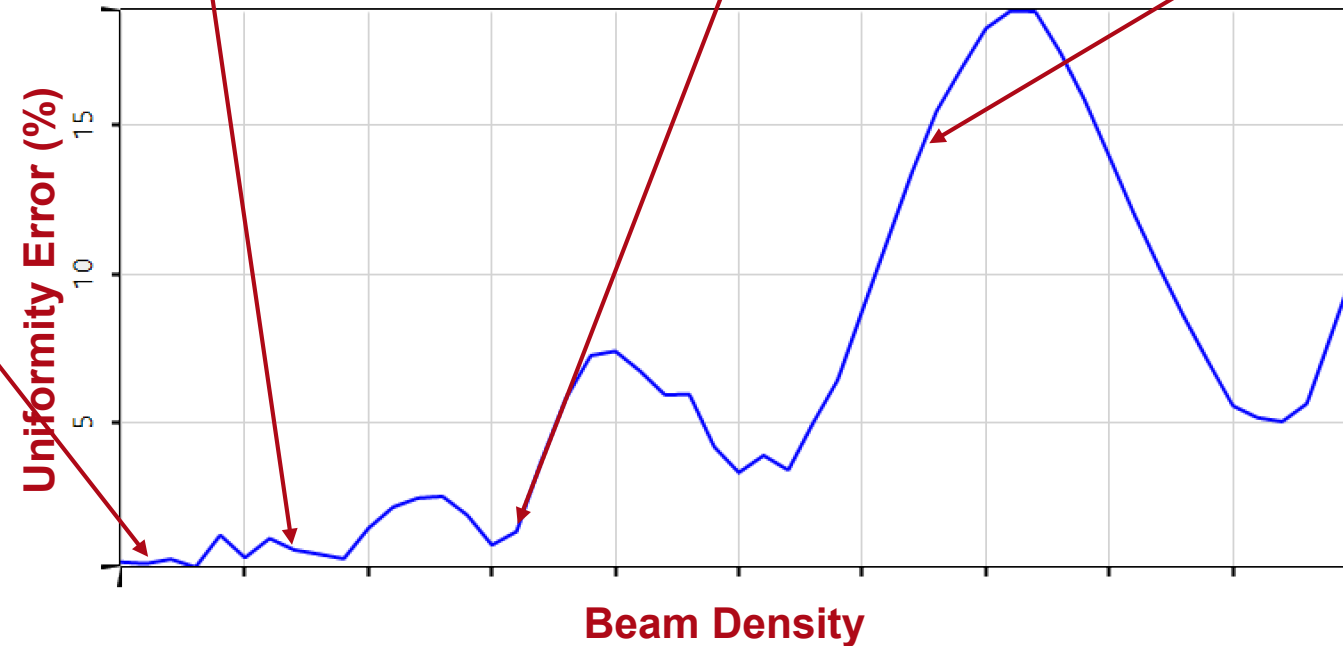

Eyebox Uniformity vs. Beam Density: Bandwidth 10nm

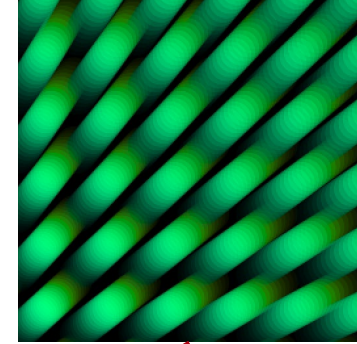
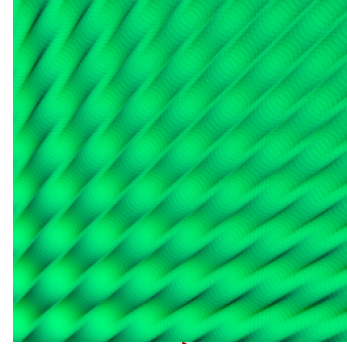
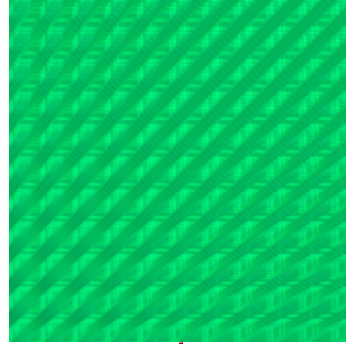
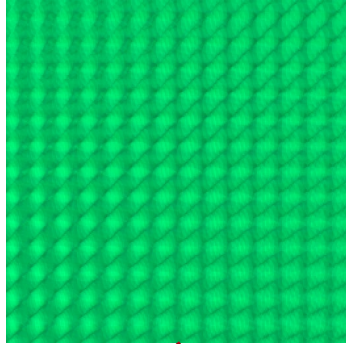

Source

- Plane Wave ($0^\circ, 0^\circ$)
- **Bandwidth – 10nm**

Detector:

- Eye Pupil Diameter - 4.5mm
- Number Eye Positions - 21 x 21

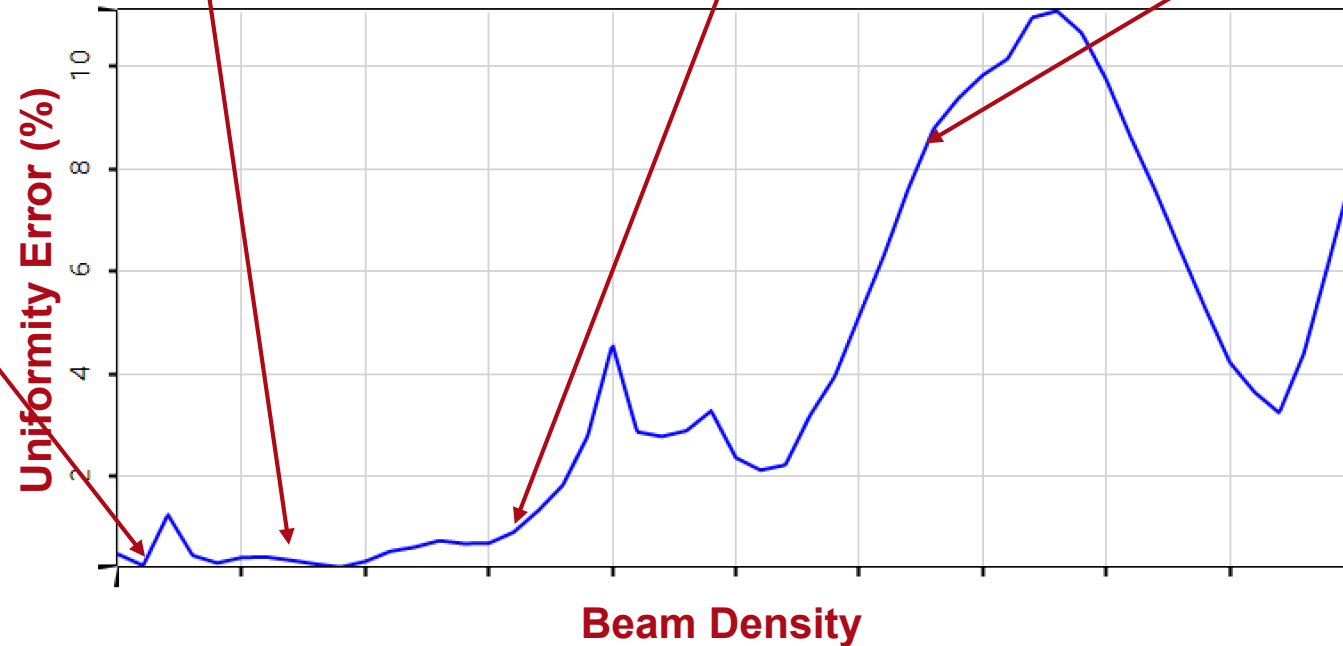

Eyebox Uniformity vs. Beam Density: Bandwidth 10nm

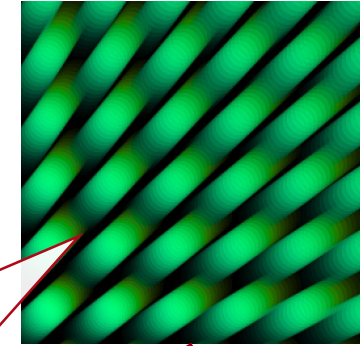
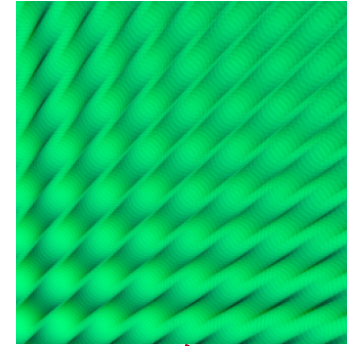
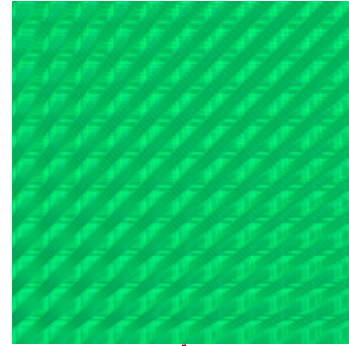
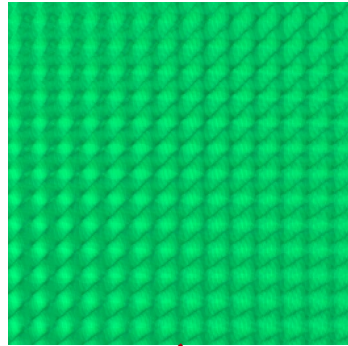

Source

- Plane Wave ($0^\circ, 0^\circ$)
- **Bandwidth – 10nm**

Detector:

- Eye Pupil Diameter - 4.5mm
- Number Eye Positions - 21 x 21

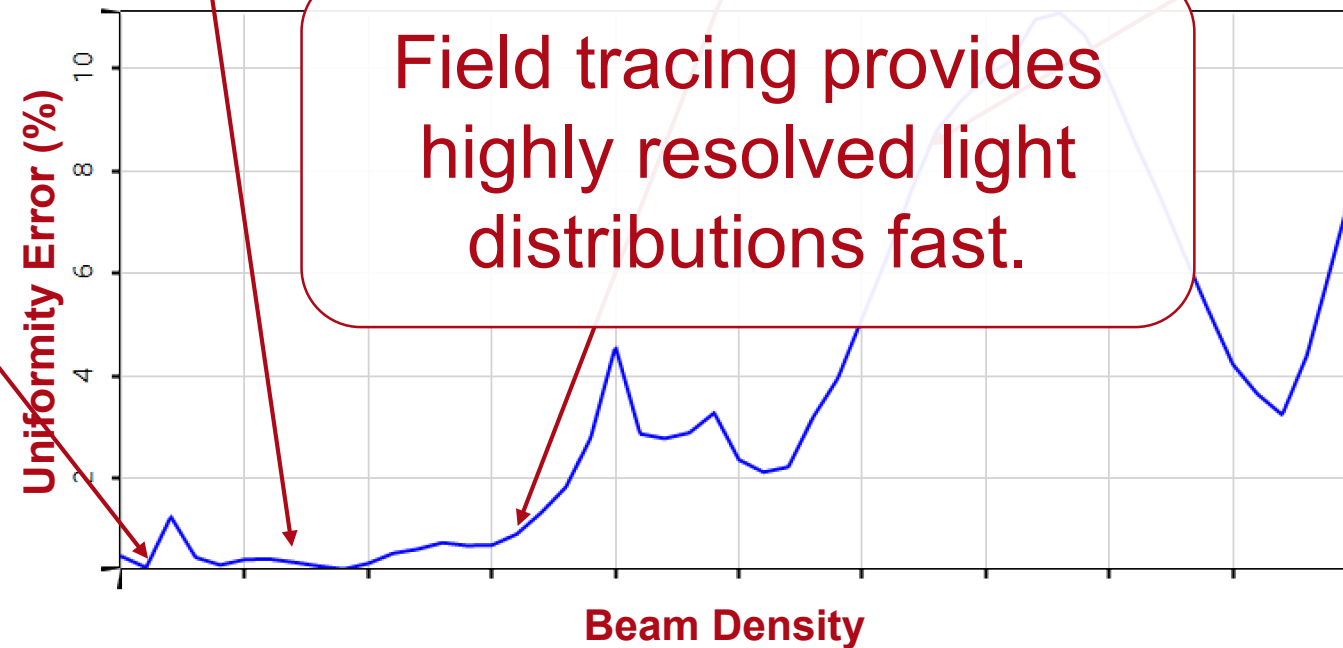

Uniformity vs. Beam Density – Comparison Bandwidths

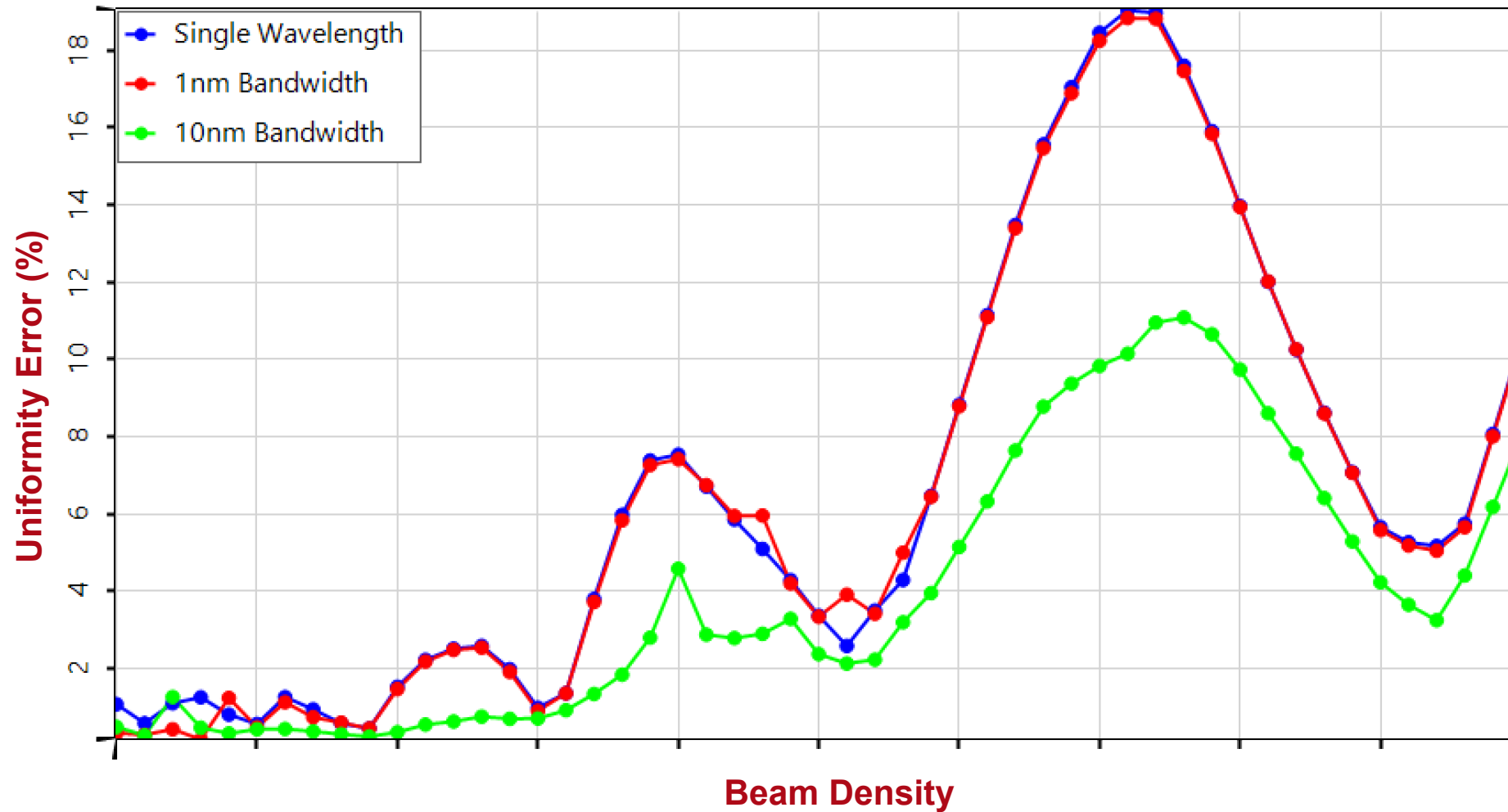

Eyebox Uniformity vs. Beam Density: FOV 1

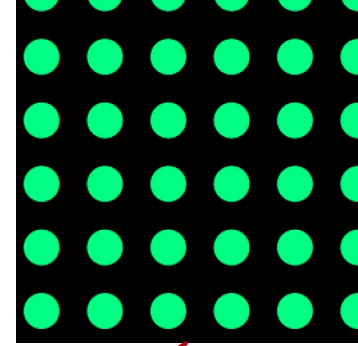
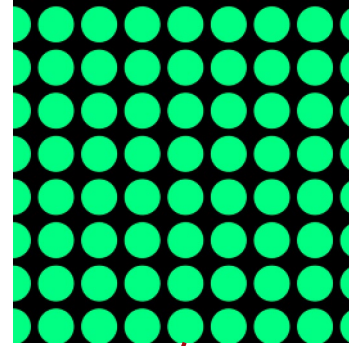
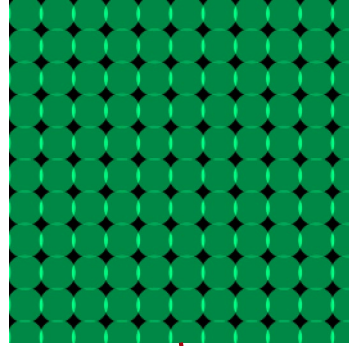
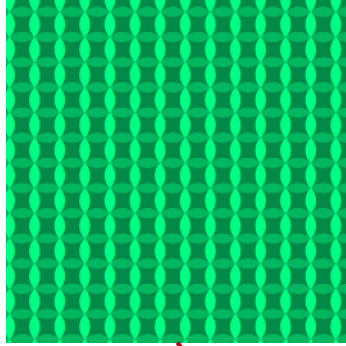

Source

- Plane Wave ($0^\circ, 0^\circ$)
- Single Wavelength (532nm)

Detector:

- Eye Pupil Diameter - 4.5mm
- Number Eye Positions - 21 x 21

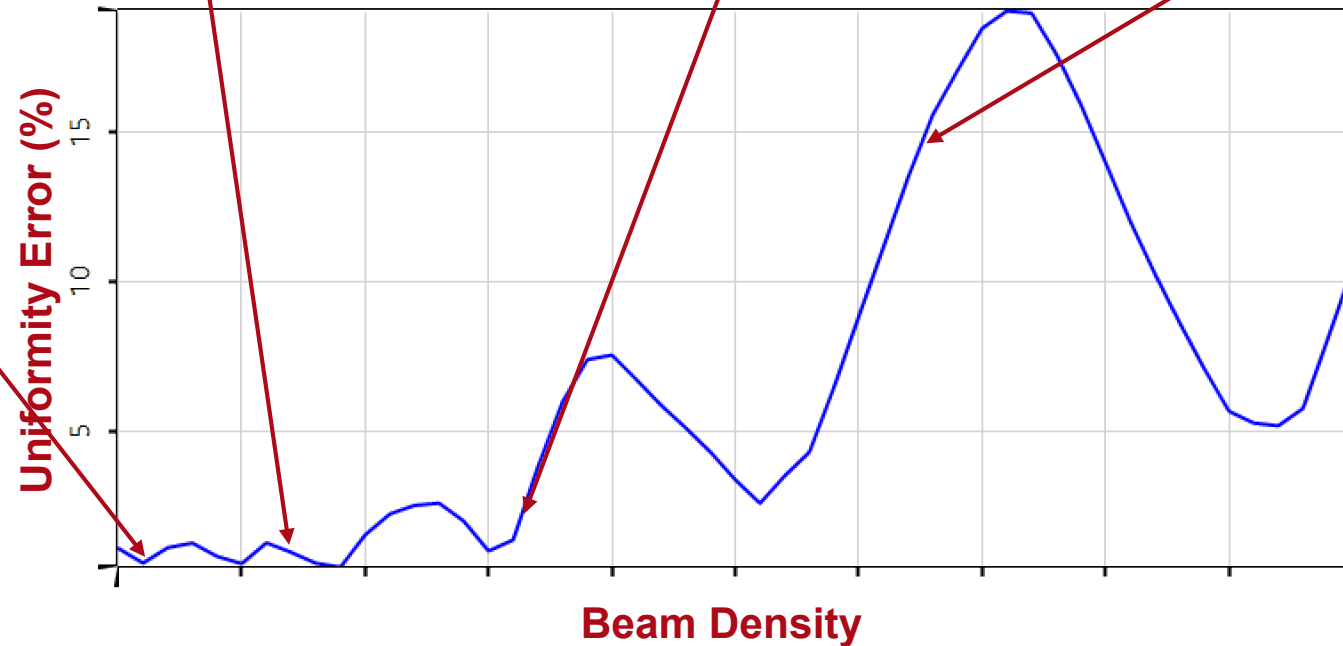

Eyebox Uniformity vs. Beam Density: FOV 2

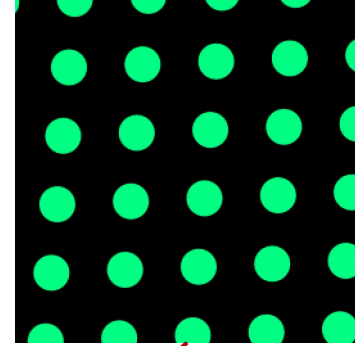
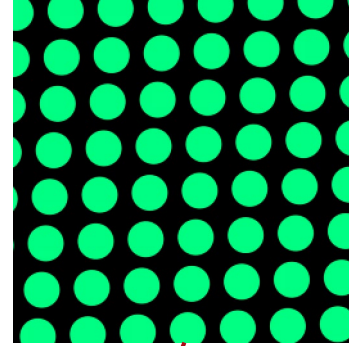
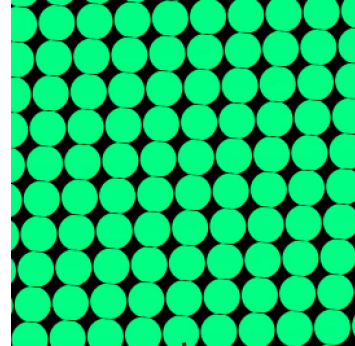
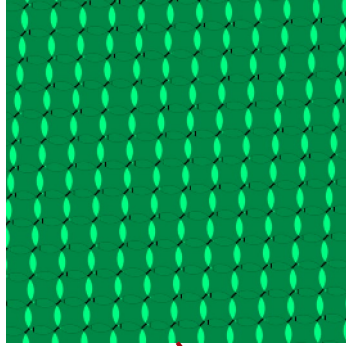

Source

- Plane Wave ($6^\circ, 3^\circ$)
- Single Wavelength (532nm)

Detector:

- Eye Pupil Diameter - 4.5mm
- Number Eye Positions - 21 x 21

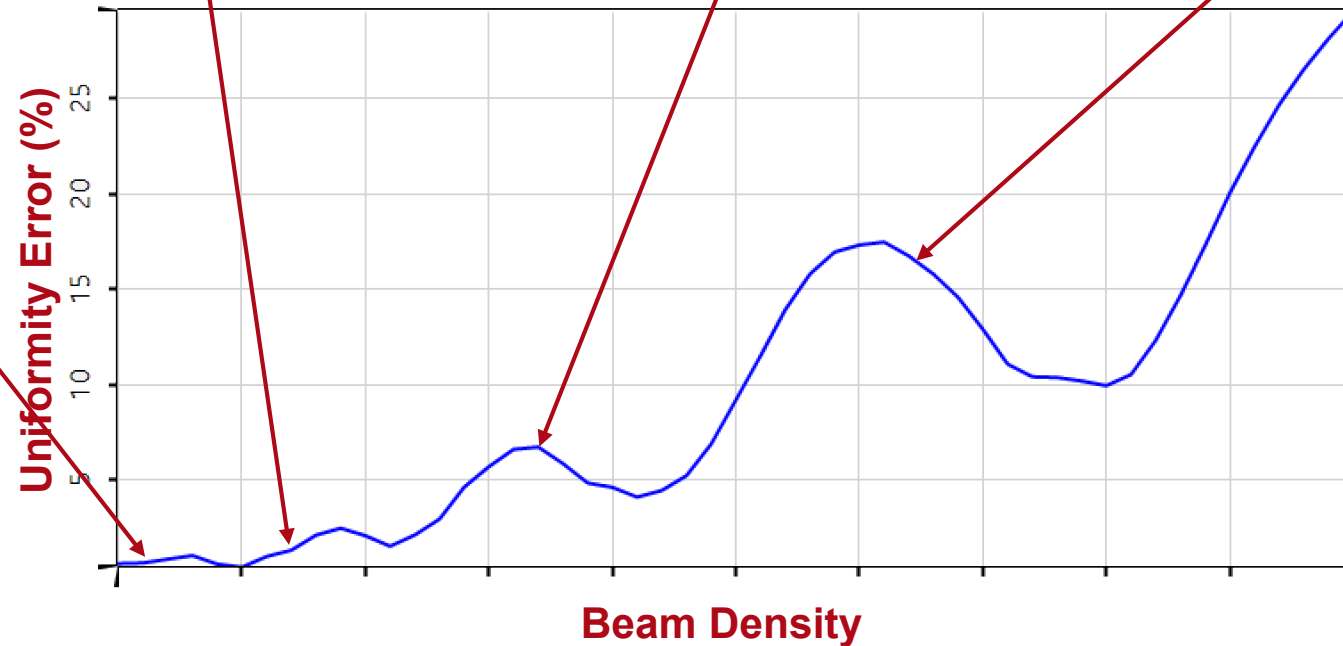

Eyebox Uniformity vs. Beam Density: FOV 3

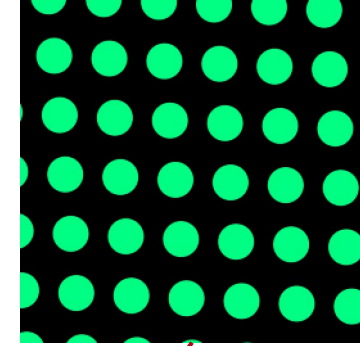
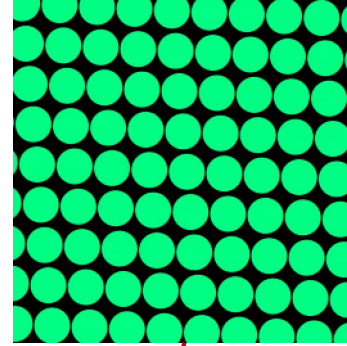
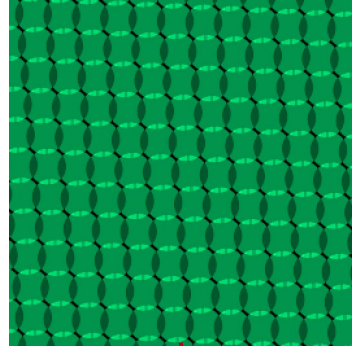
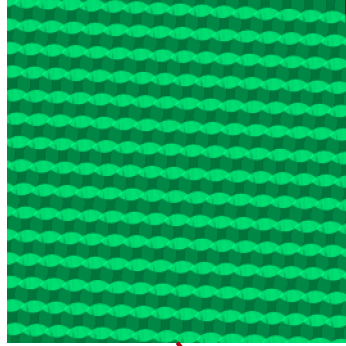

Source

- Plane Wave (-6°, -3°)
- Single Wavelength (532nm)

Detector:

- Eye Pupil Diameter - 4.5mm
- Number Eye Positions - 21 x 21

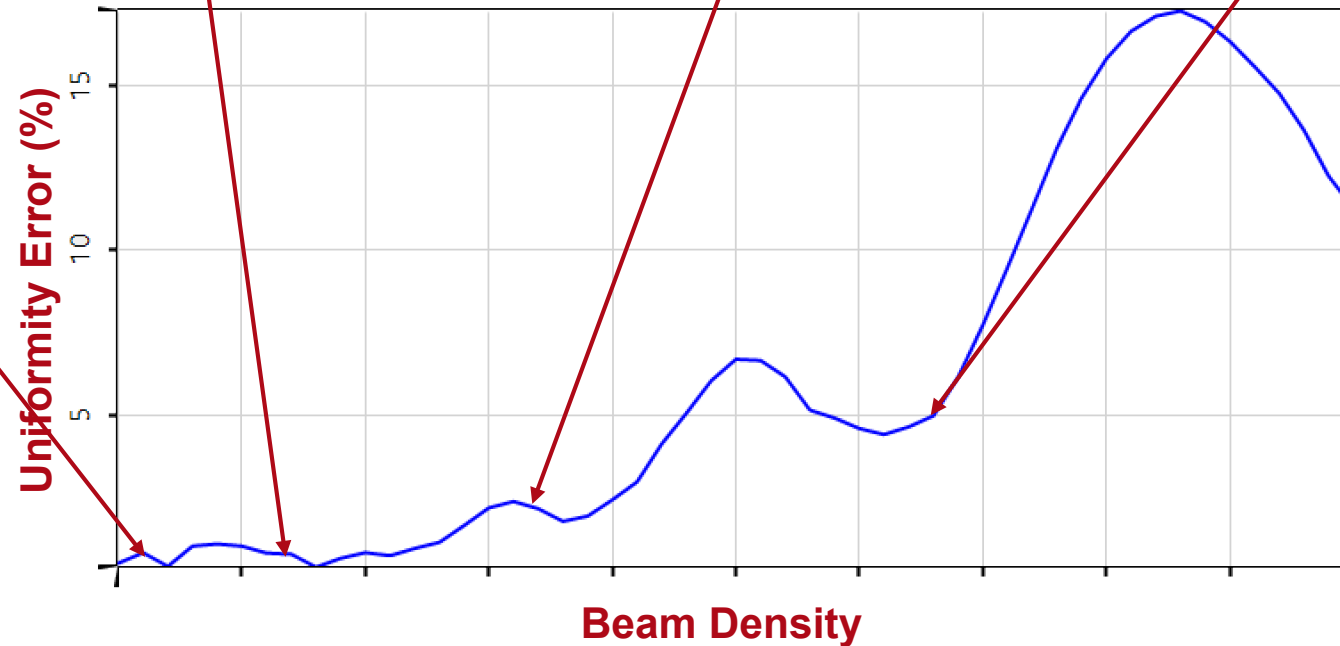

Uniformity vs. Beam Density: Comparison Different FOVs

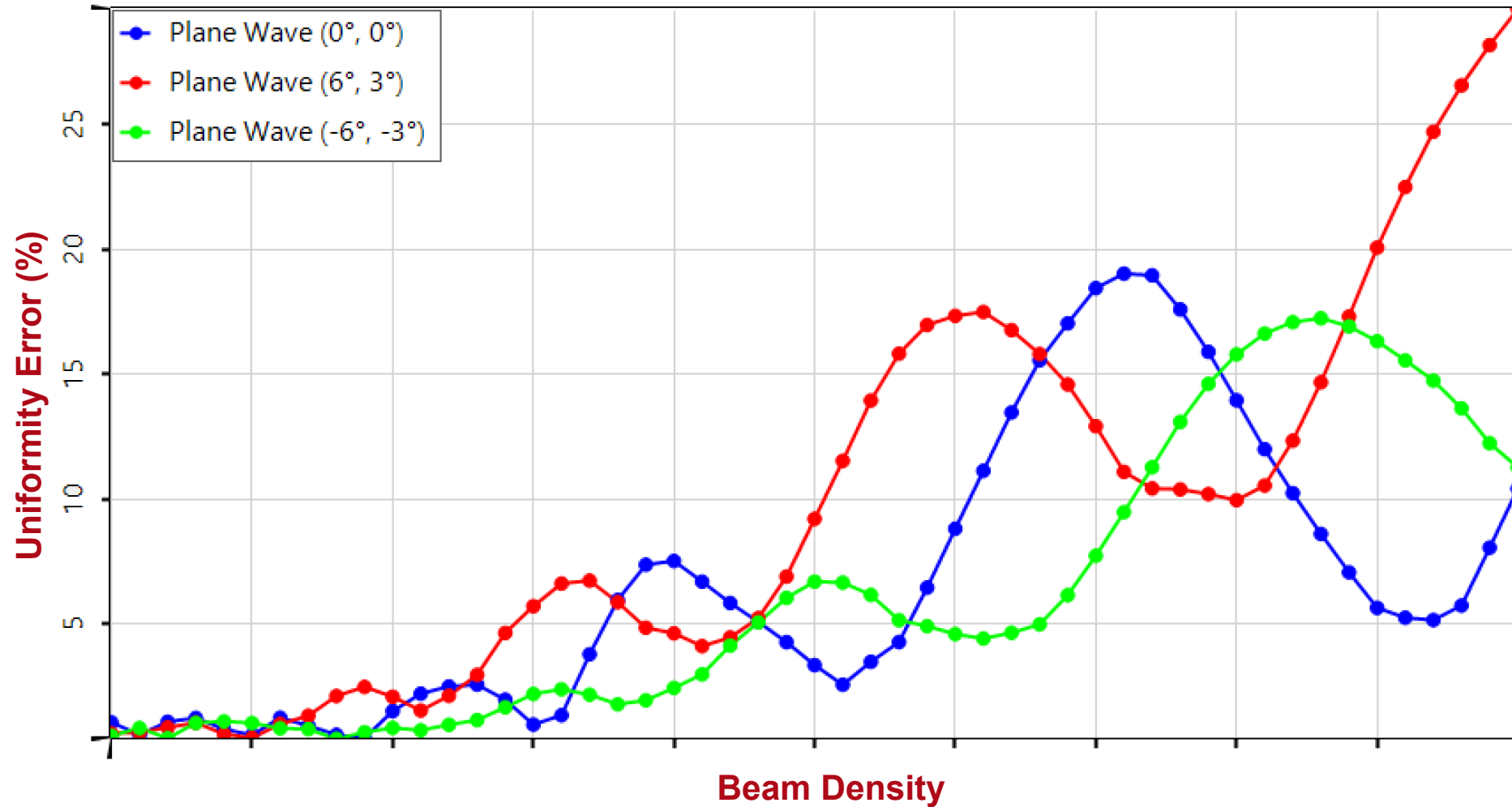

Lightguide Modeling and Design: Grating Optimization

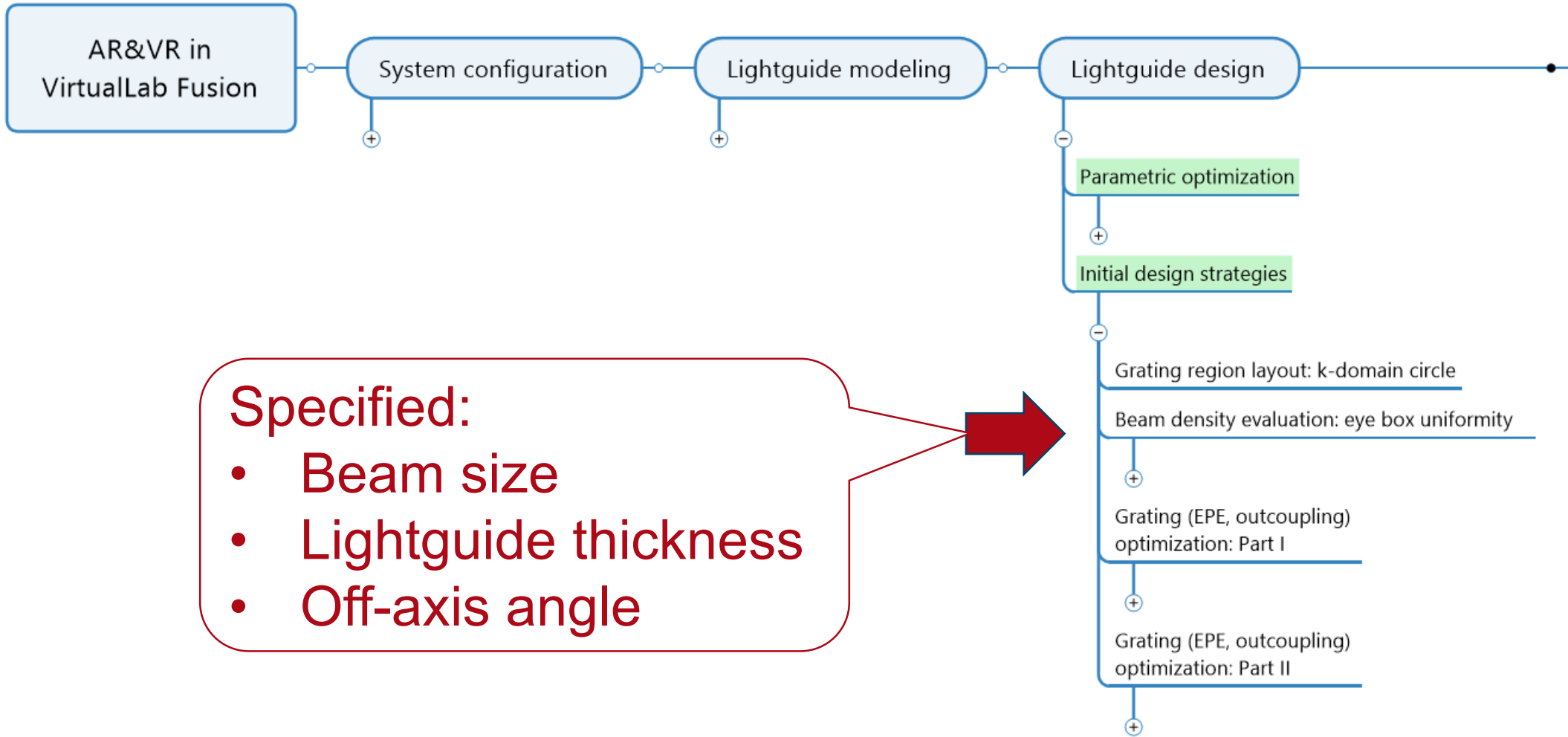

Lightguide Modeling and Design: Grating Optimization

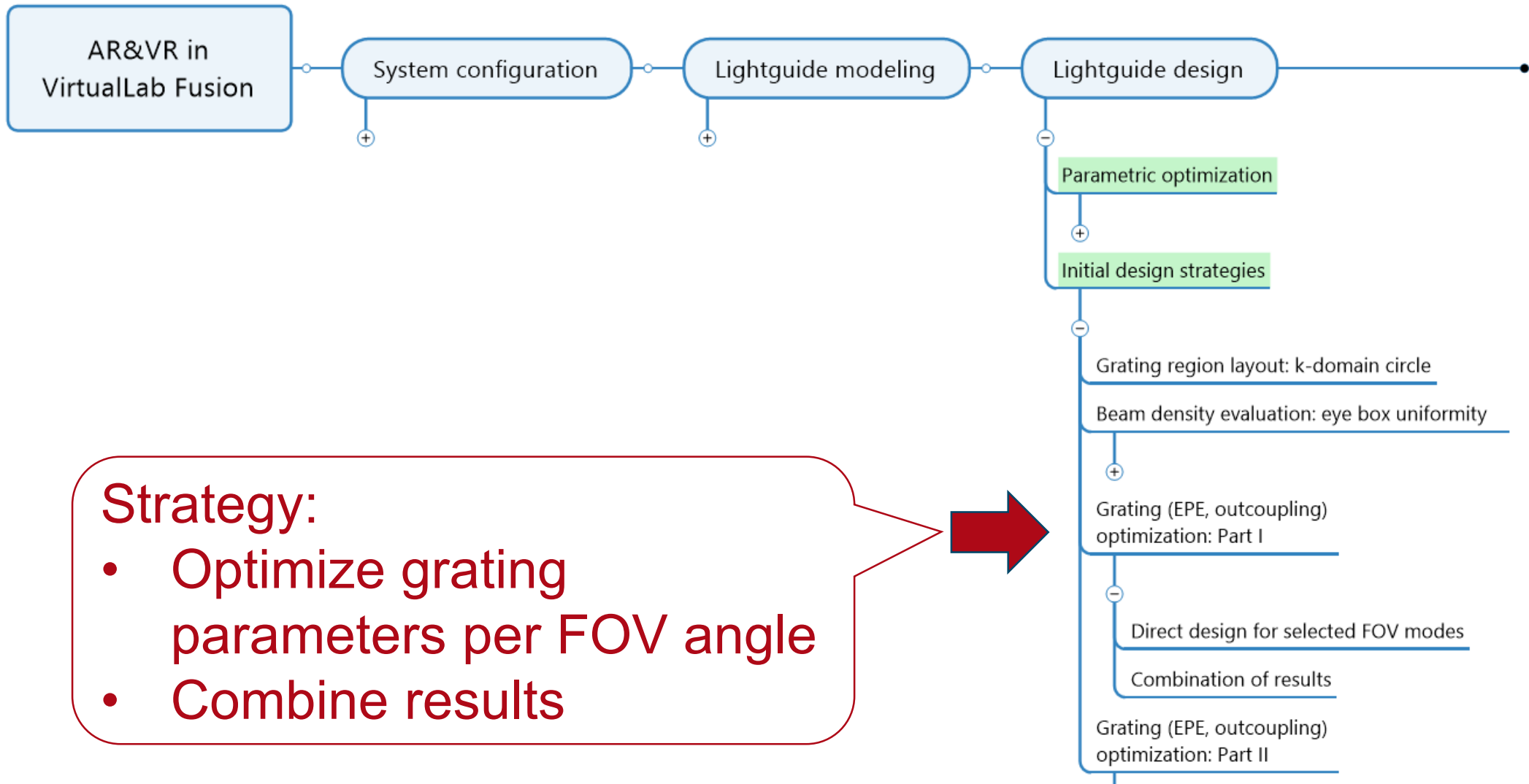

Grating Design for FOV Angle (0°, 0°)

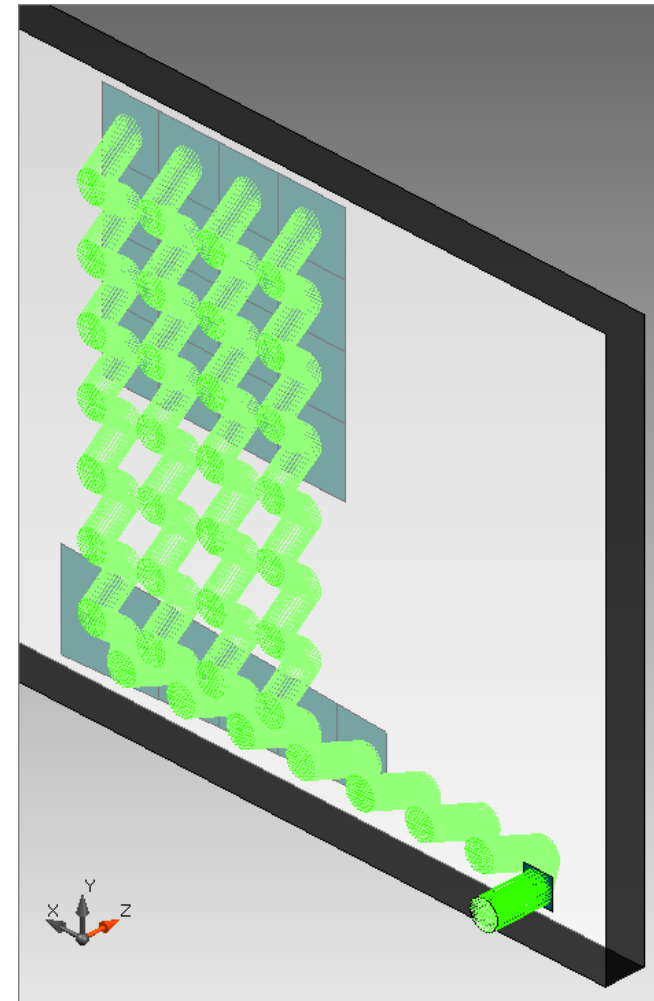
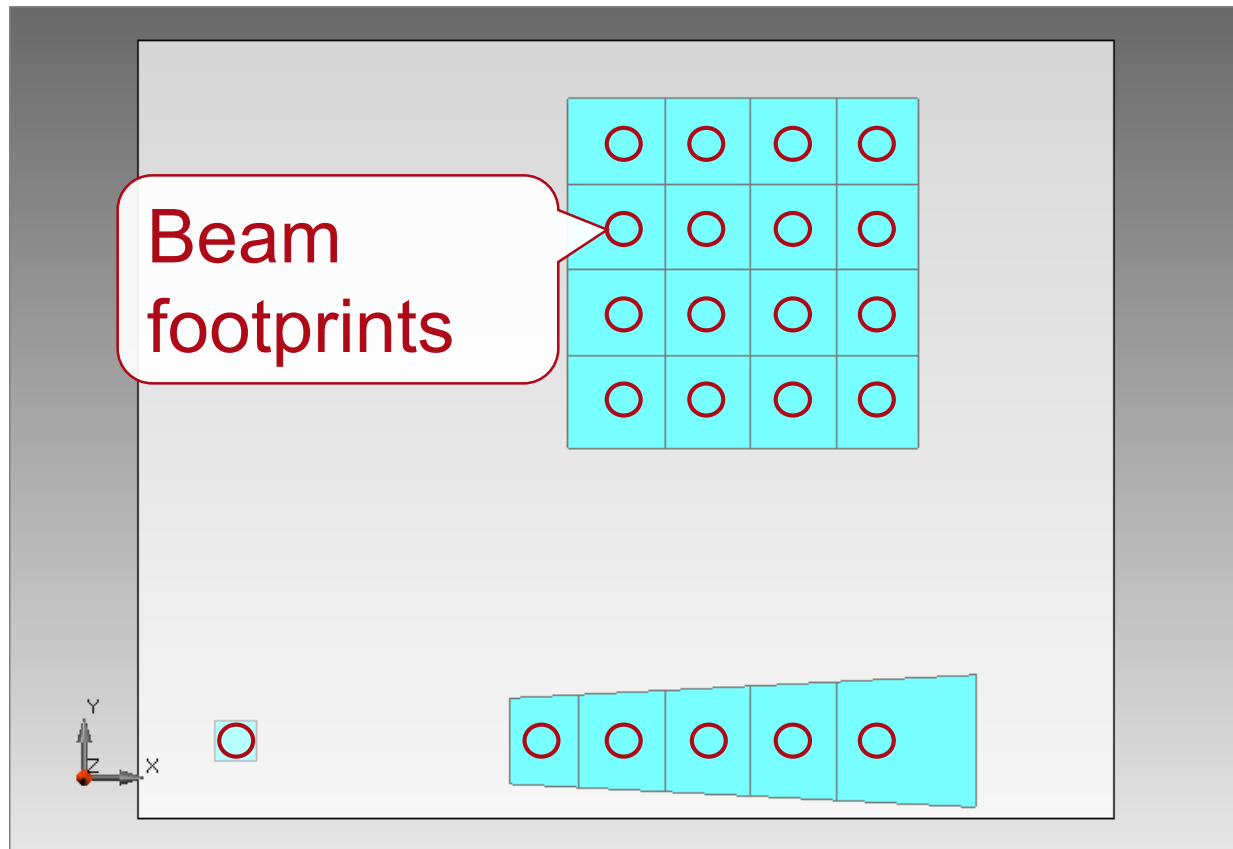

Grating Design per FOV Angle: Flux Control

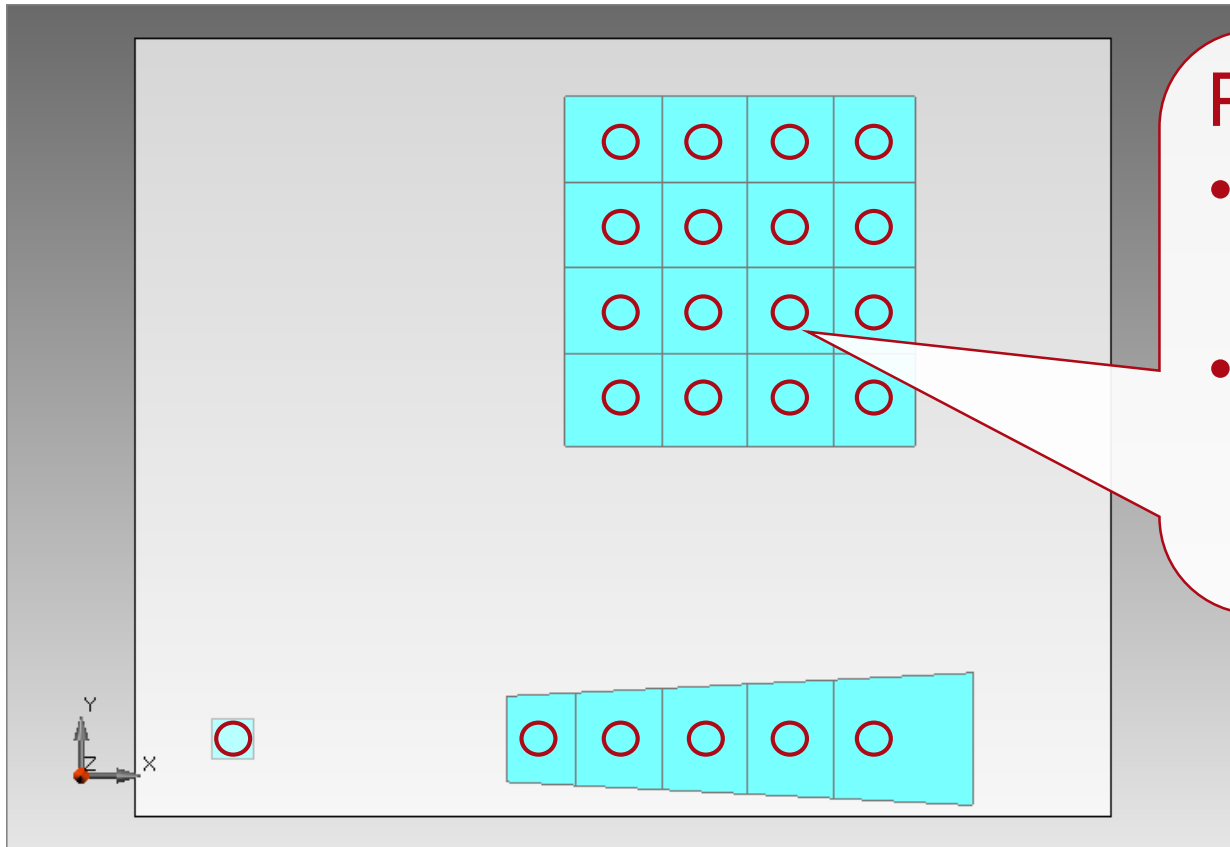

Per footprint of beam:

- Control percental flux into required directions
- Optimize local grating parameters to obtain required flux

Grating Design per FOV Angle: Grating Analysis and Selection

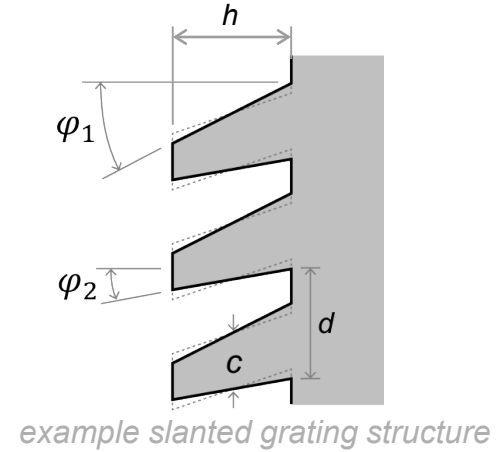
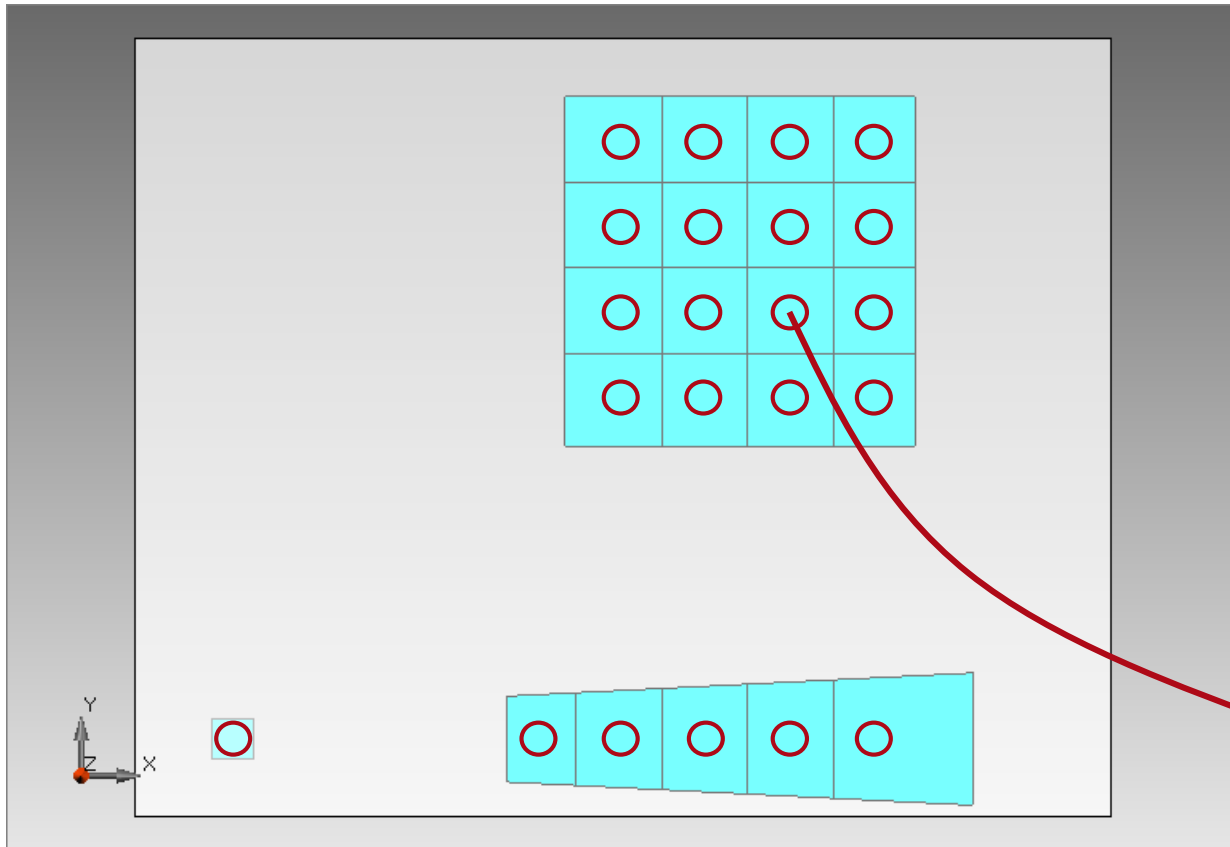

Calculation of Rayleigh matrix for given input beam parameters

$$\begin{pmatrix} E_{x,out} \\ E_{y,out} \end{pmatrix}_{k_{out,m}} = \begin{bmatrix} R_{xx} & R_{yx} \\ R_{xy} & R_{yy} \end{bmatrix} \cdot \begin{pmatrix} E_{x,arb,in} \\ E_{y,arb,in} \end{pmatrix}_{k_{in}}$$

Grating Design per FOV Angle: Grating Analysis and Selection

Scan of grating parameters: Fill factor (x) and height (y)

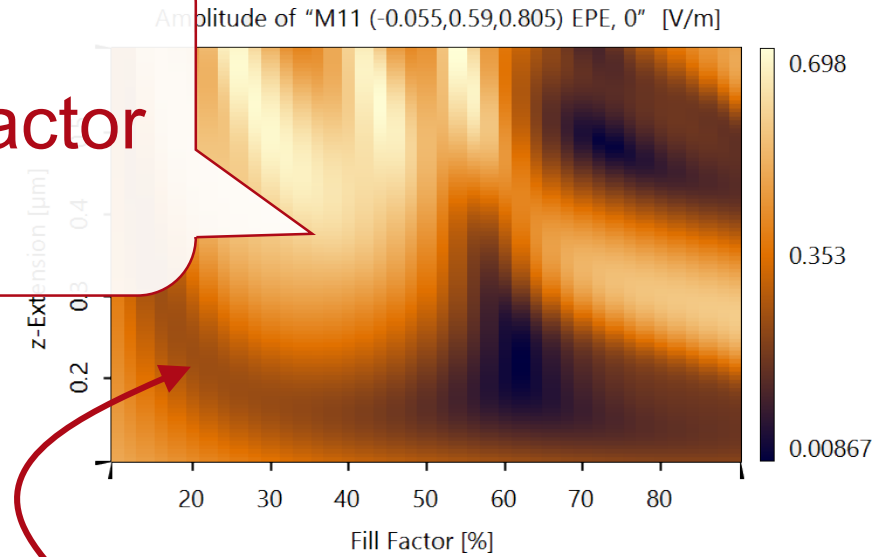
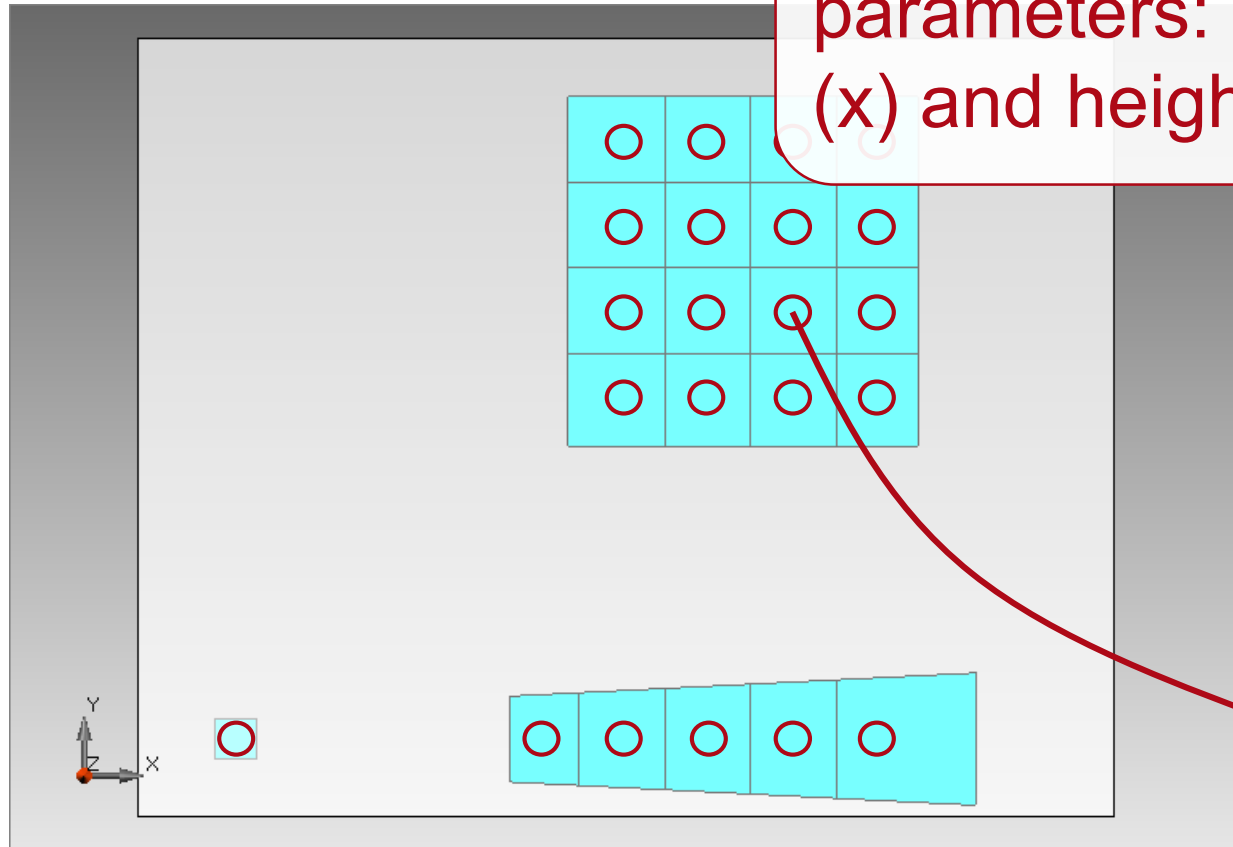

Calculation of Rayleigh matrix for given input beam parameters

$$\begin{pmatrix} E_{x,out} \\ E_{y,out} \end{pmatrix}_{k_{out,m}} = \begin{bmatrix} R_{xx} & R_{yx} \\ R_{xy} & R_{yy} \end{bmatrix} \cdot \begin{pmatrix} E_{x,arb,in} \\ E_{y,arb,in} \end{pmatrix}_{k_{in}}$$

Grating Design per FOV Angle: Grating Analysis and Selection

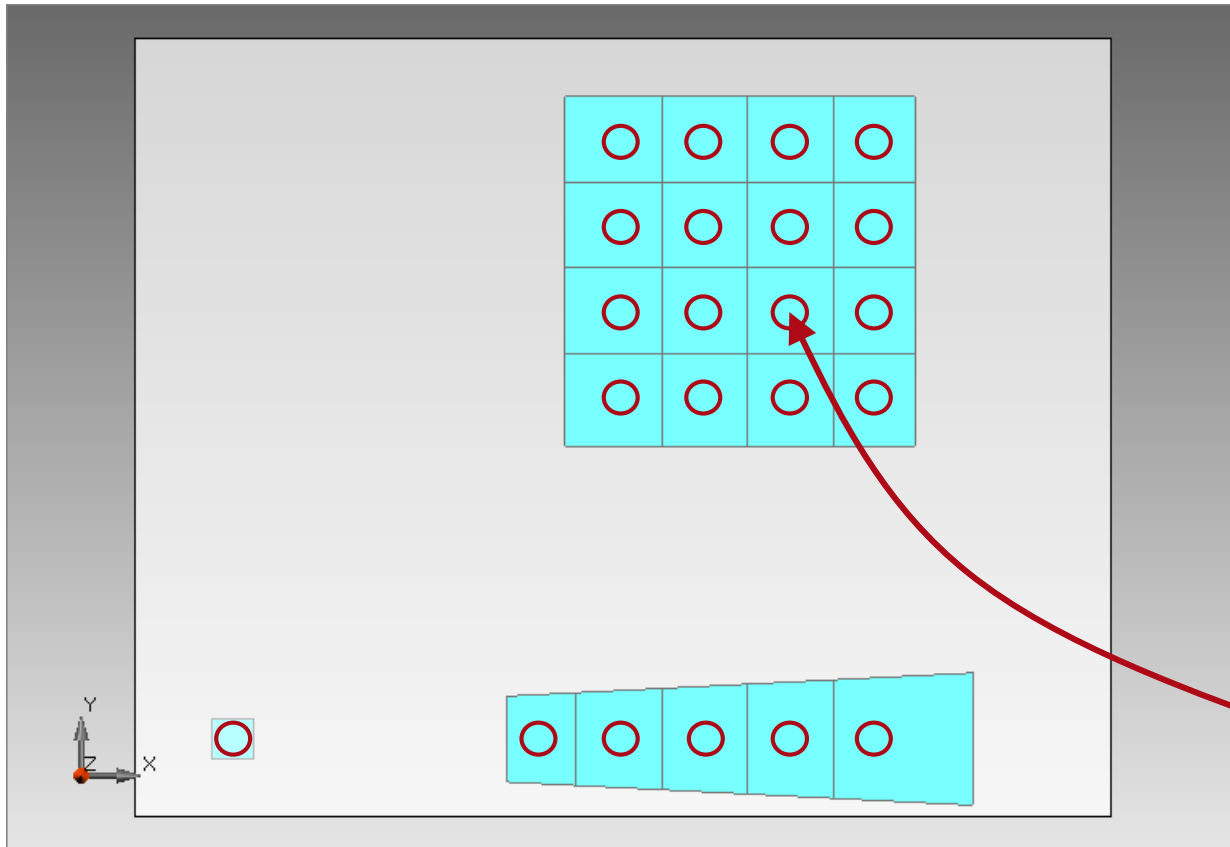

- Selection of grating parameters per footprint to obtain required fluxes.

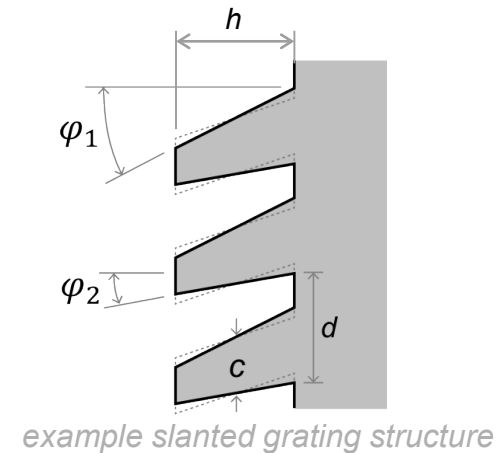

Grating Design per FOV Angle: Grating Analysis and Selection

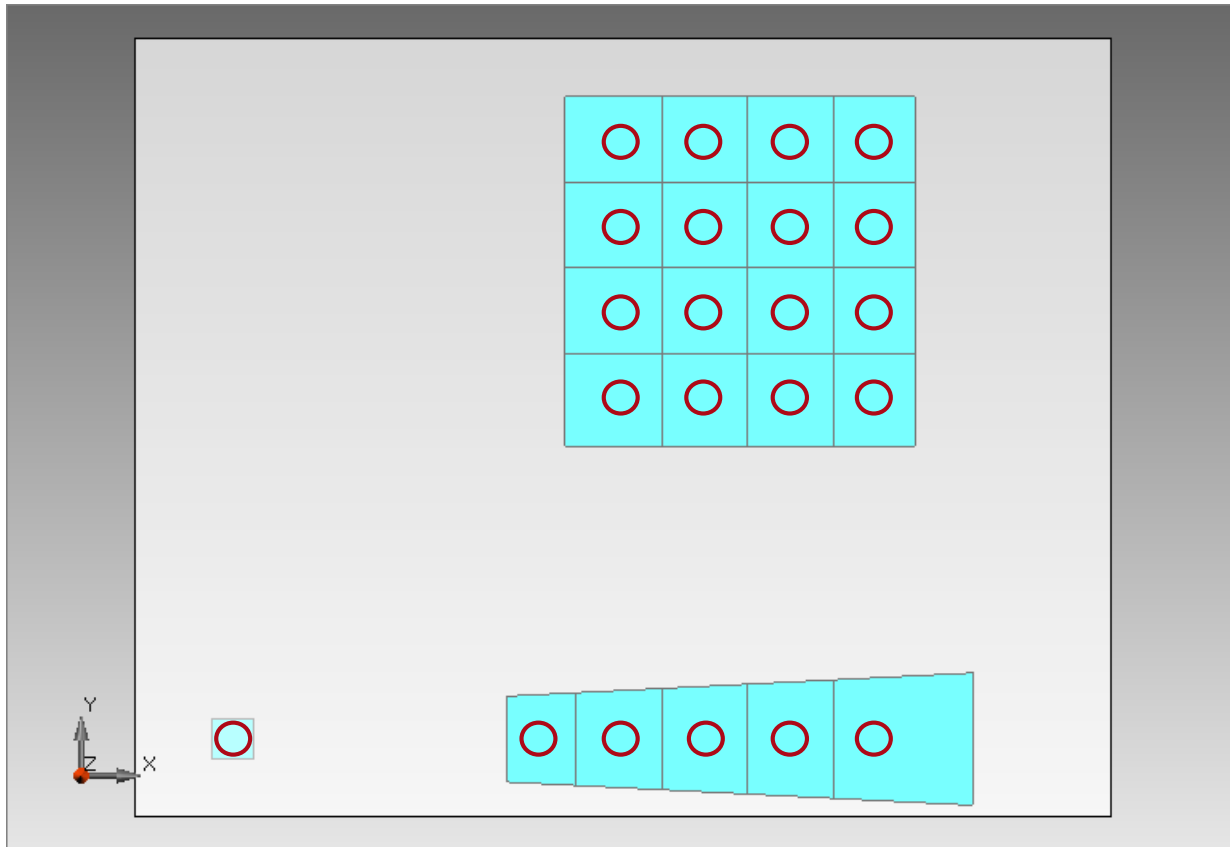

$$\begin{pmatrix} E_{x,out} \\ E_{y,out} \end{pmatrix}_{k_{out,m}} = \begin{bmatrix} R_{xx} & R_{yx} \\ R_{xy} & R_{yy} \end{bmatrix} \cdot \begin{pmatrix} E_{x,arb,in} \\ E_{y,arb,in} \end{pmatrix}_{k_{in}}$$

- Storage of Rayleigh matrices in lookup table.
- Can be applied to arbitrary polarization for optimizing grating parameters.

Grating Design for FOV Angle (5° , 3°) – Polarization Evaluation

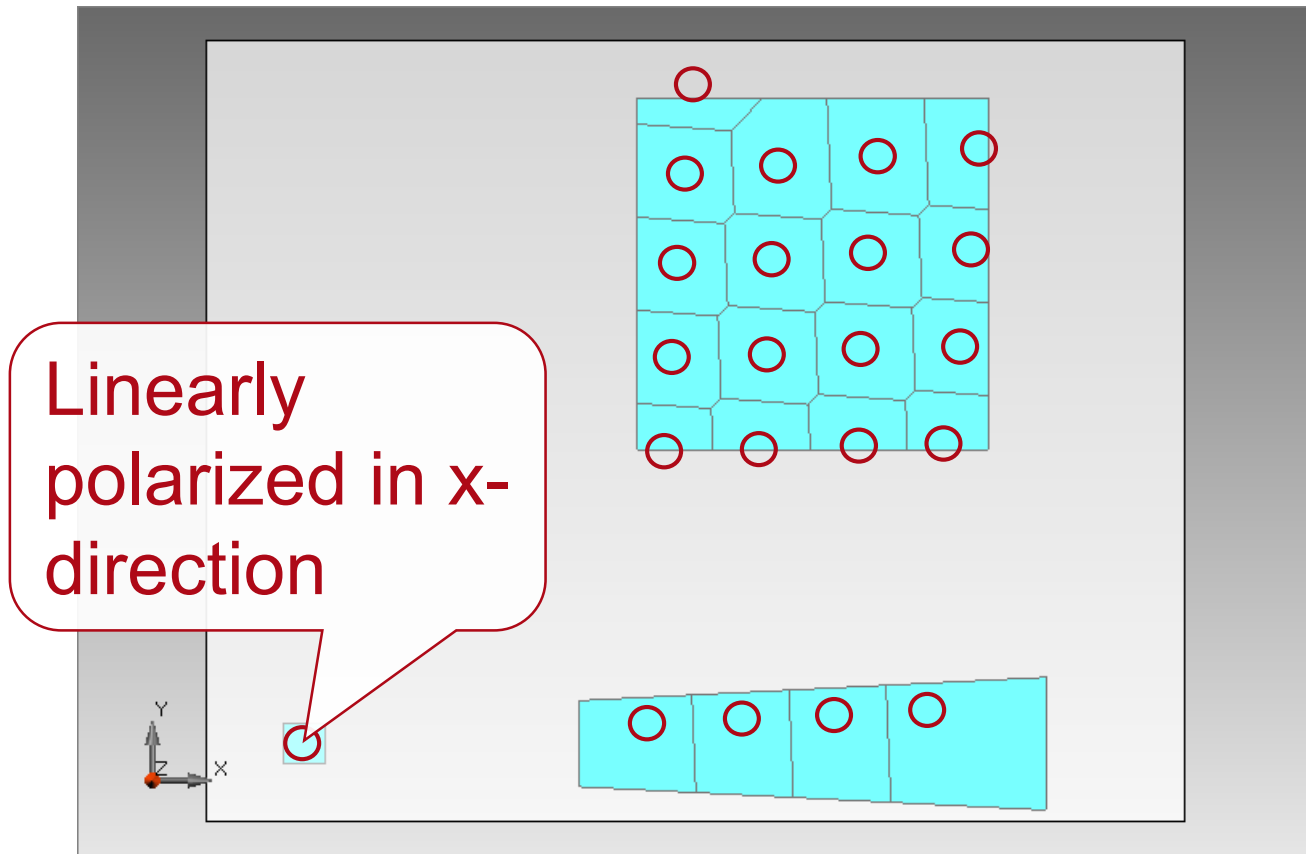

Grating Design for FOV Angle (5° , 3°) – Polarization Evaluation

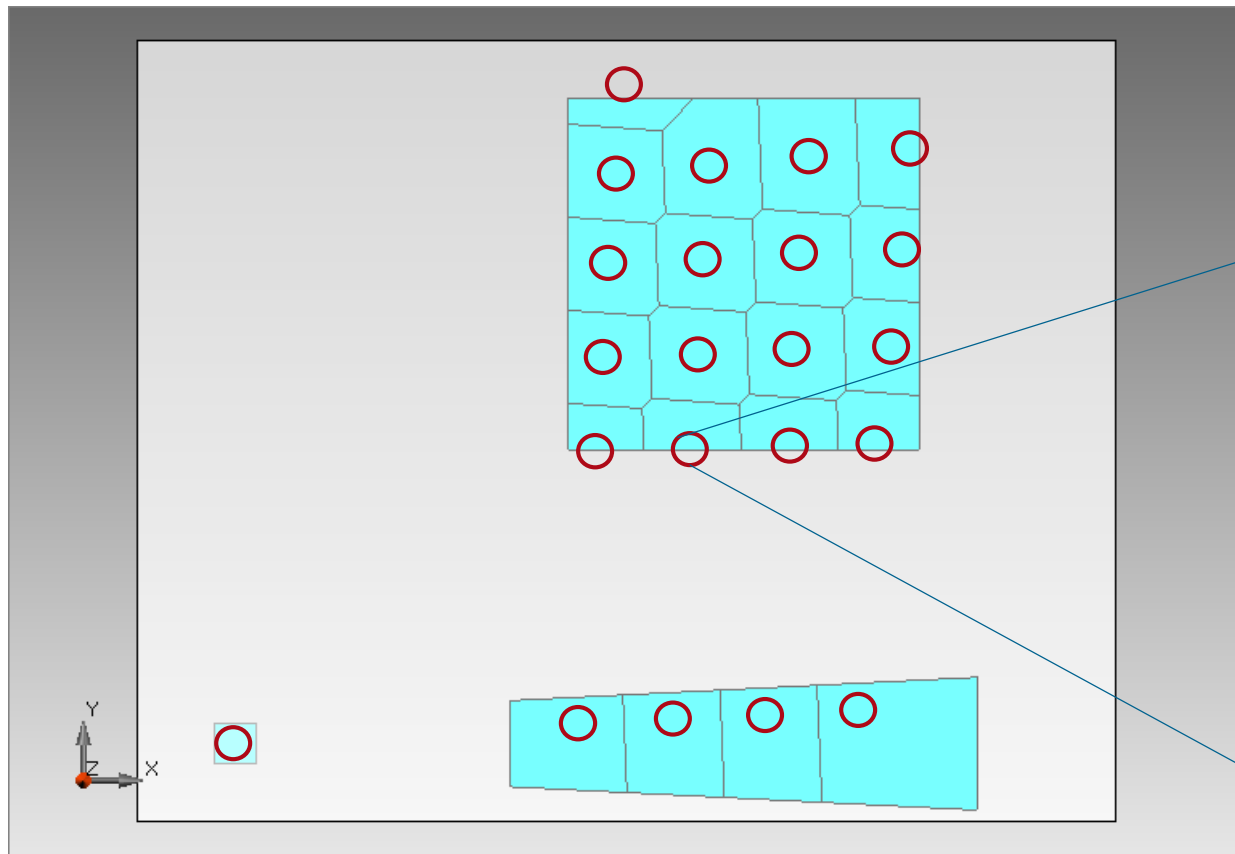

Incident light at grating interaction
(uniform polarization)

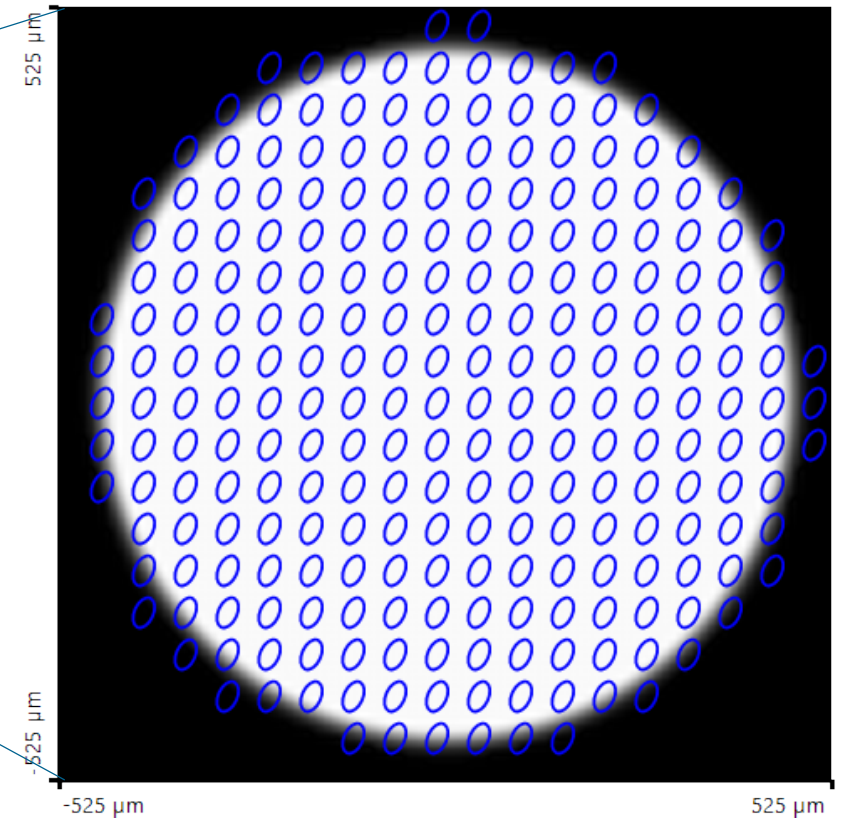

Grating Design for FOV Angle (5° , 3°) – Polarization Evaluation

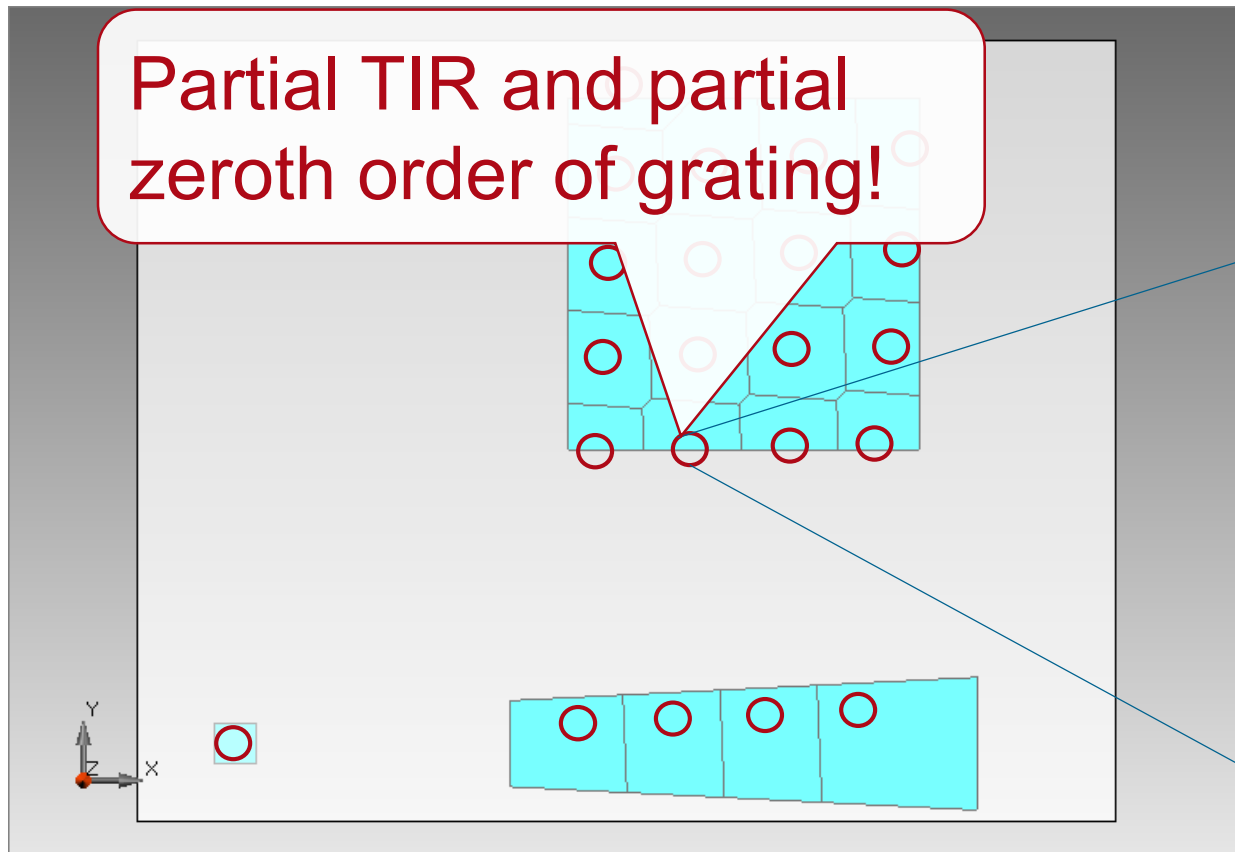

Incident light at grating interaction
(uniform polarization)

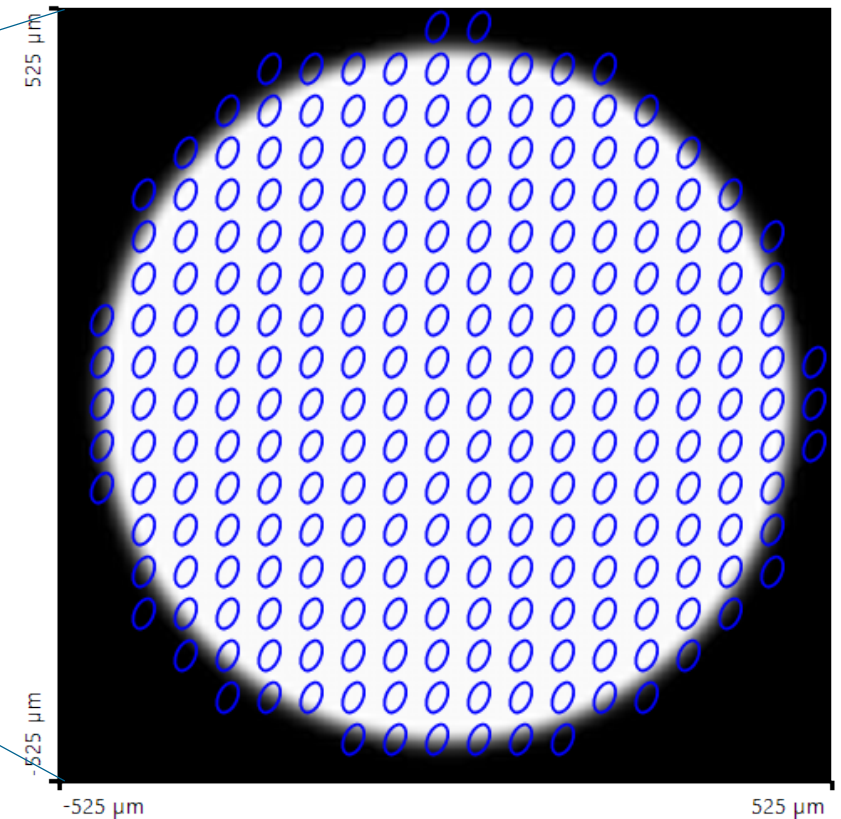

Grating Design for FOV Angle (5° , 3°) – Polarization Evaluation

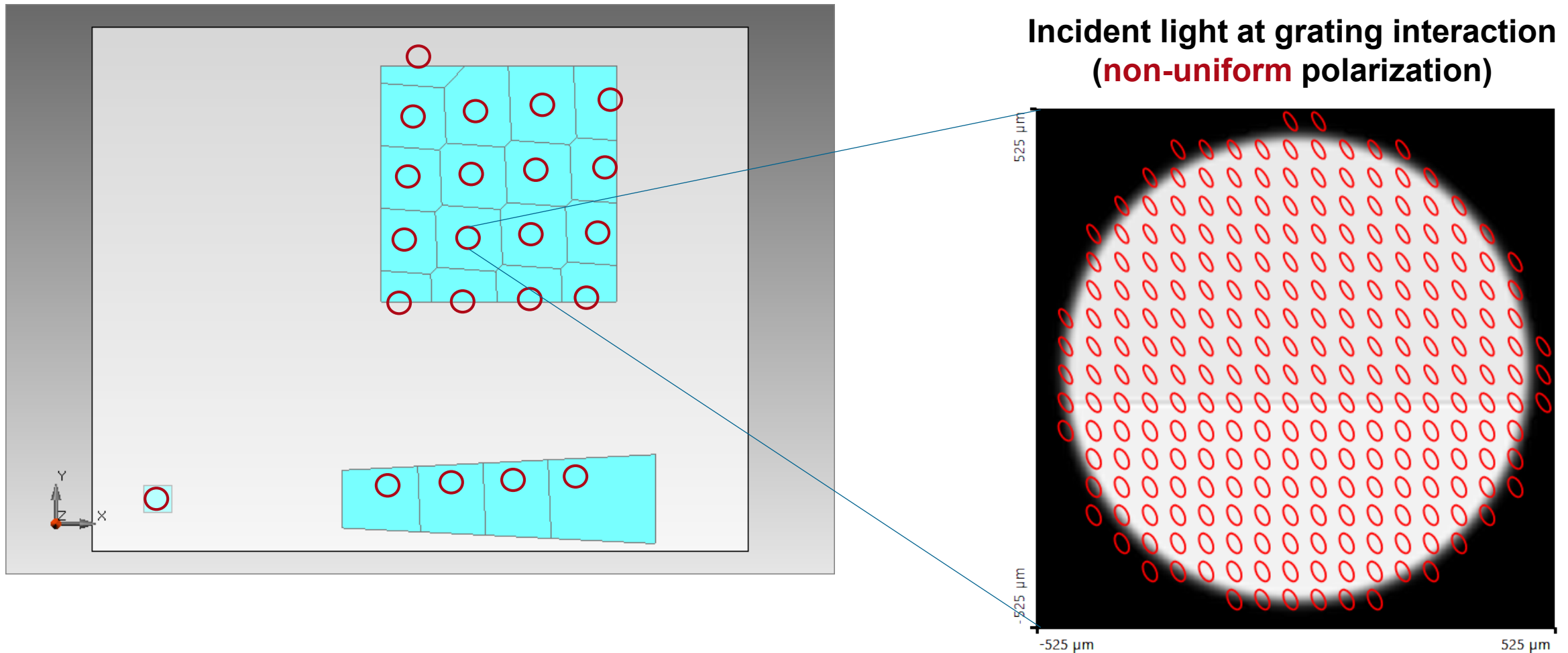

Grating Design for FOV Angle (5° , 3°) – Polarization Evaluation

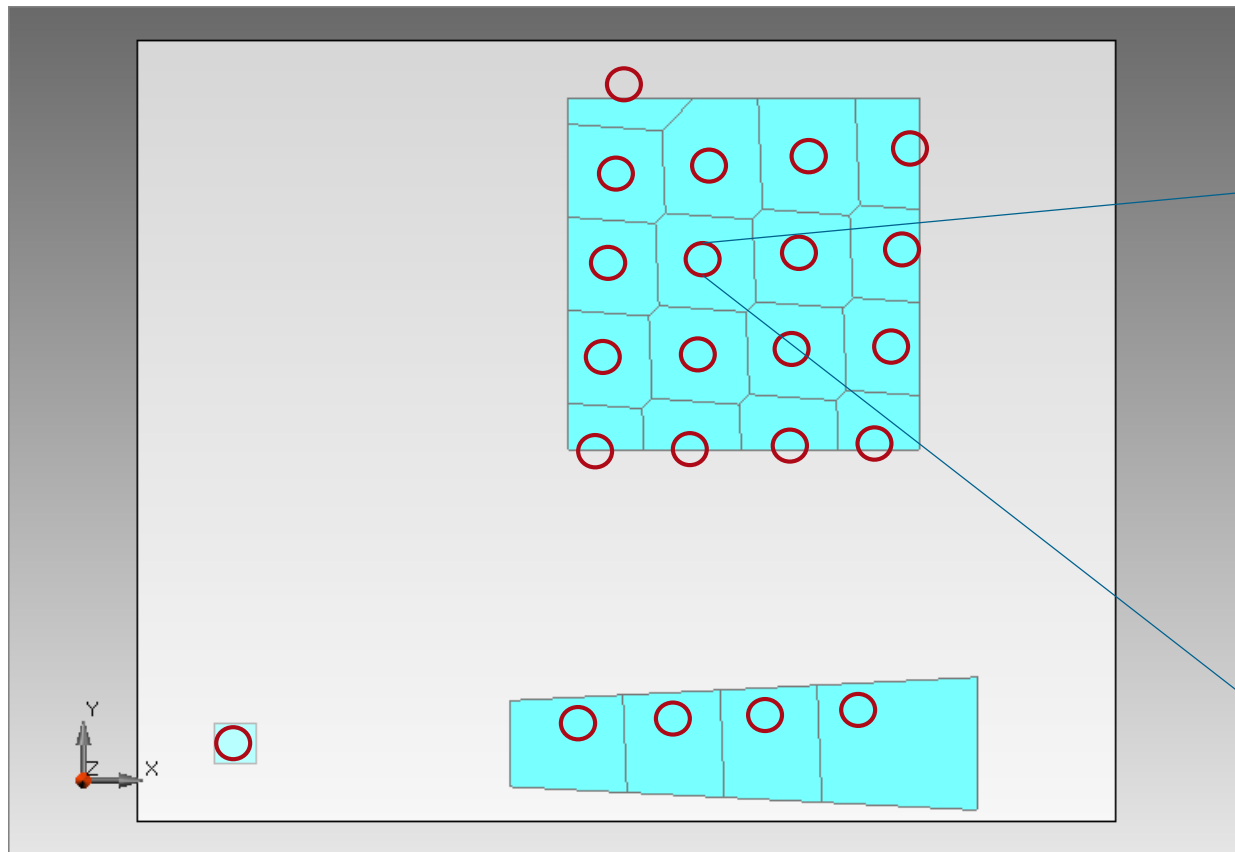

Incident light at grating interaction
(**non-uniform** polarization)

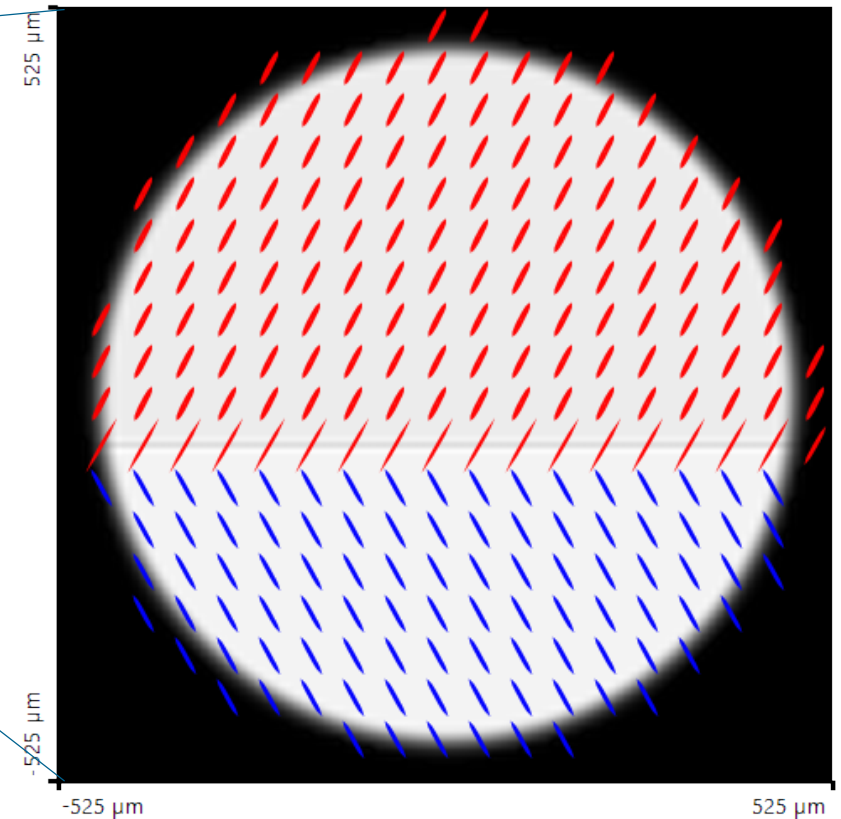

Grating Design for FOV Angle (5° , 3°) – Polarization Evaluation

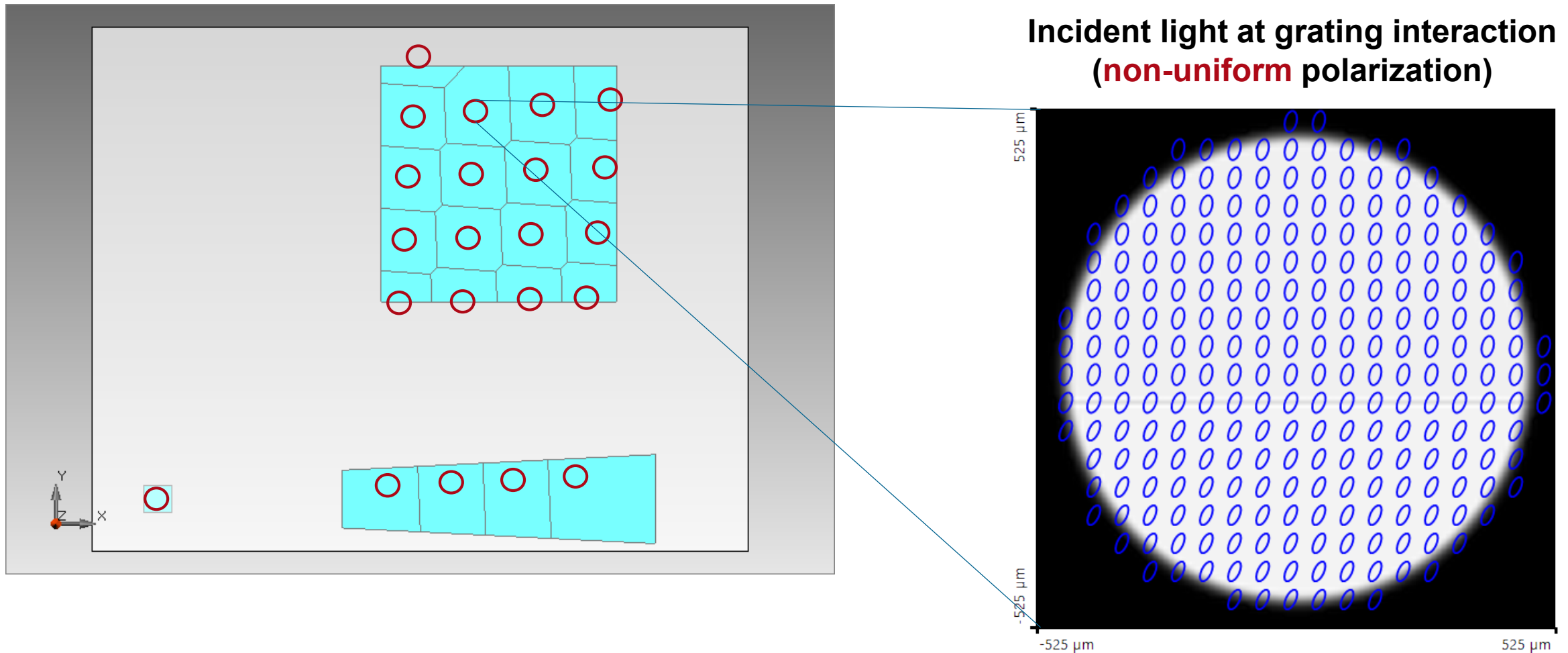

Lightguide Modeling and Design: Grating Optimization

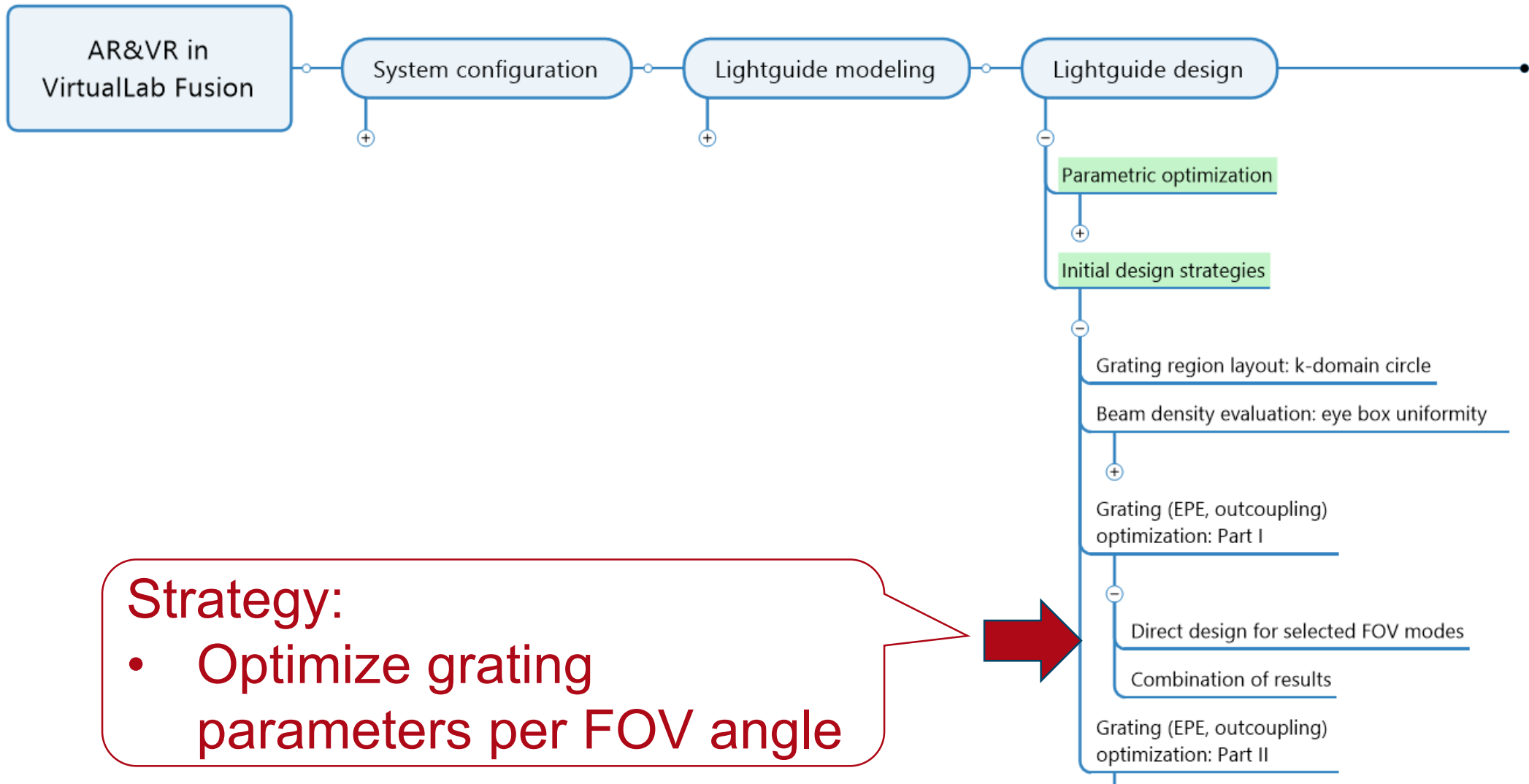

Grating Design for FOV Angle (0°, 0°)

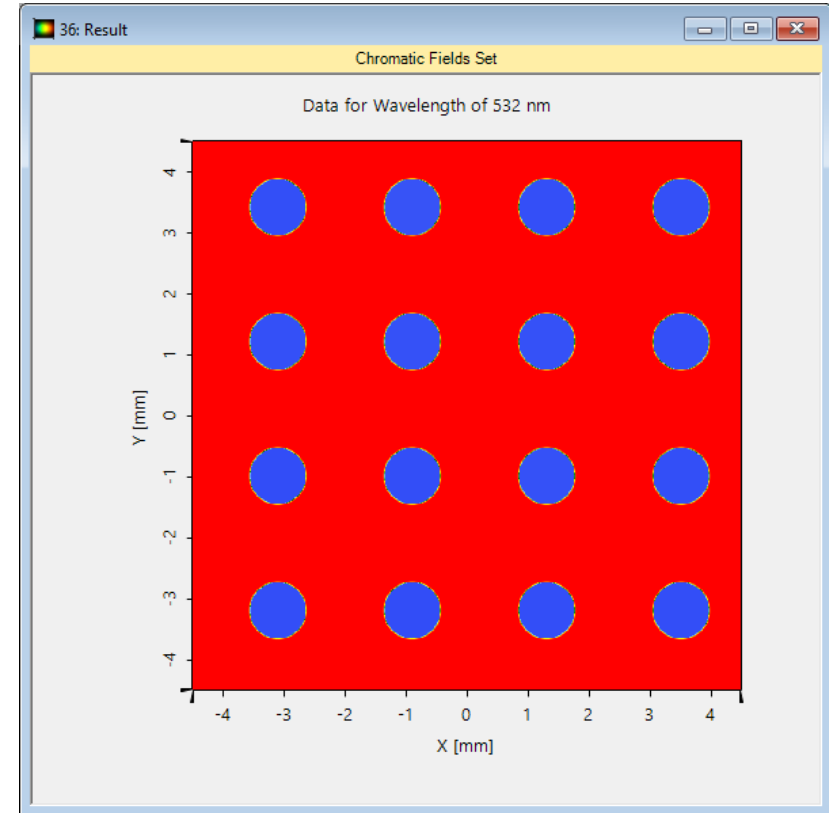
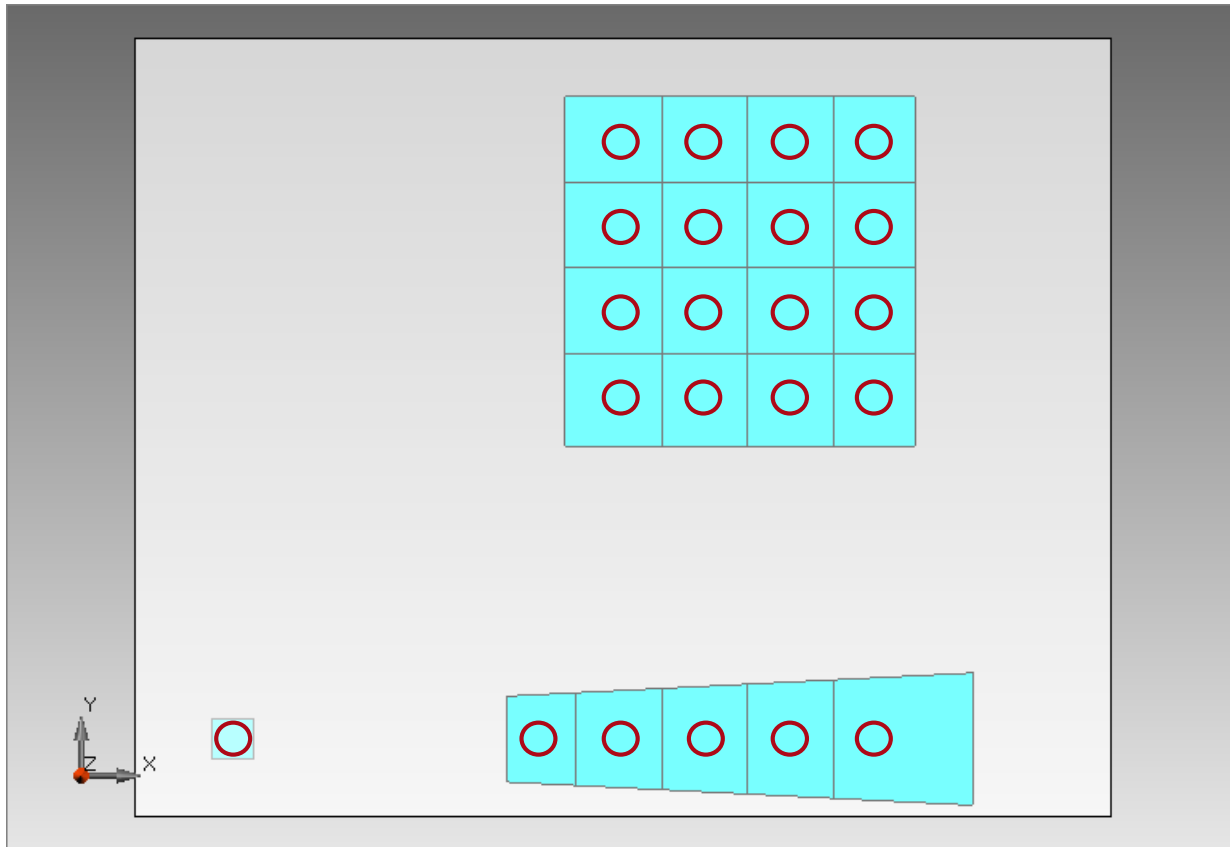

Merit Function	Value
----------------	-------

FOV Angle	$\alpha = 0^\circ ; \beta = 0^\circ$
-----------	--------------------------------------

Uniformity Error	0.34%
------------------	--------------

Optimized Grating Parameter EPE Grating

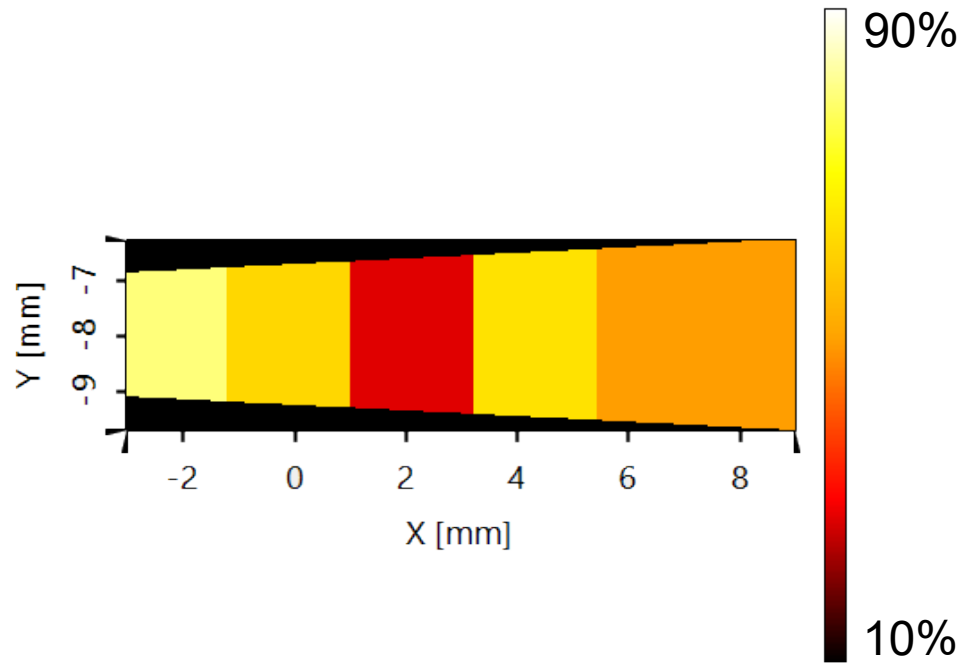

Optimized Fill Factors

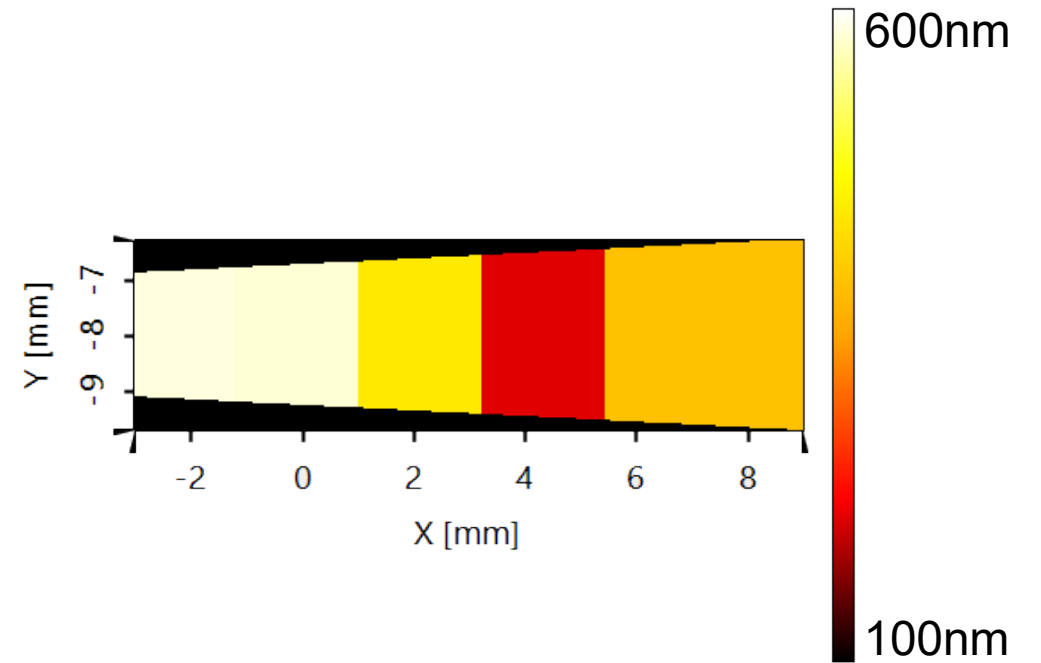

Optimized Modulation Depth

Optimized Grating Parameter Outcoupling Grating

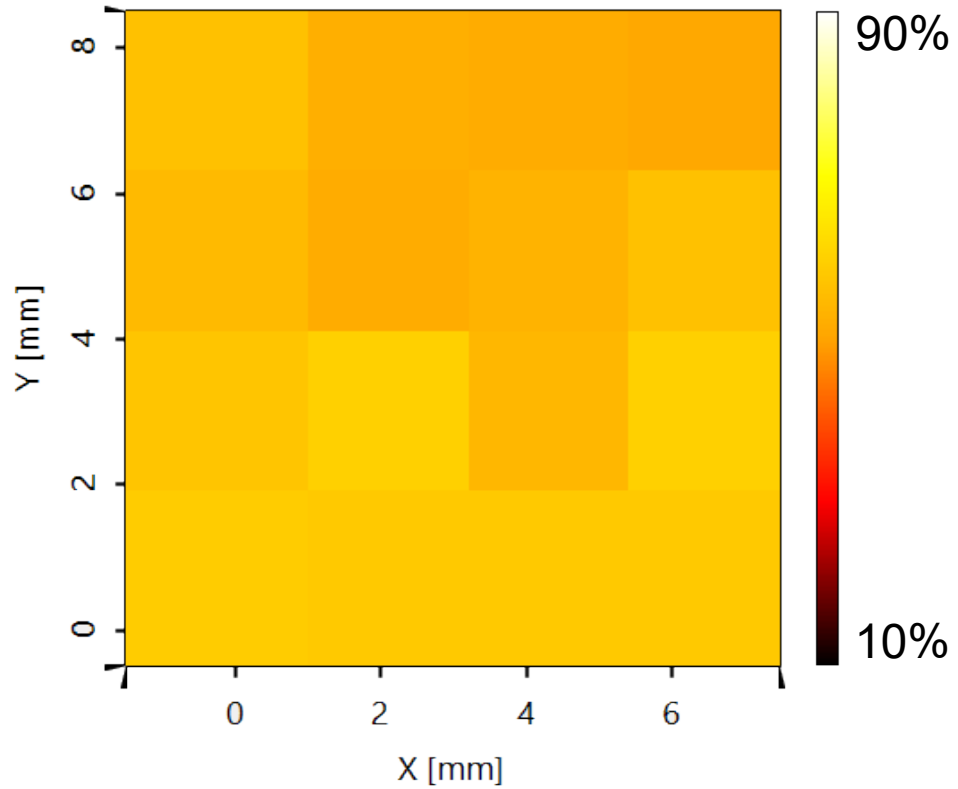

Optimized Fill Factors

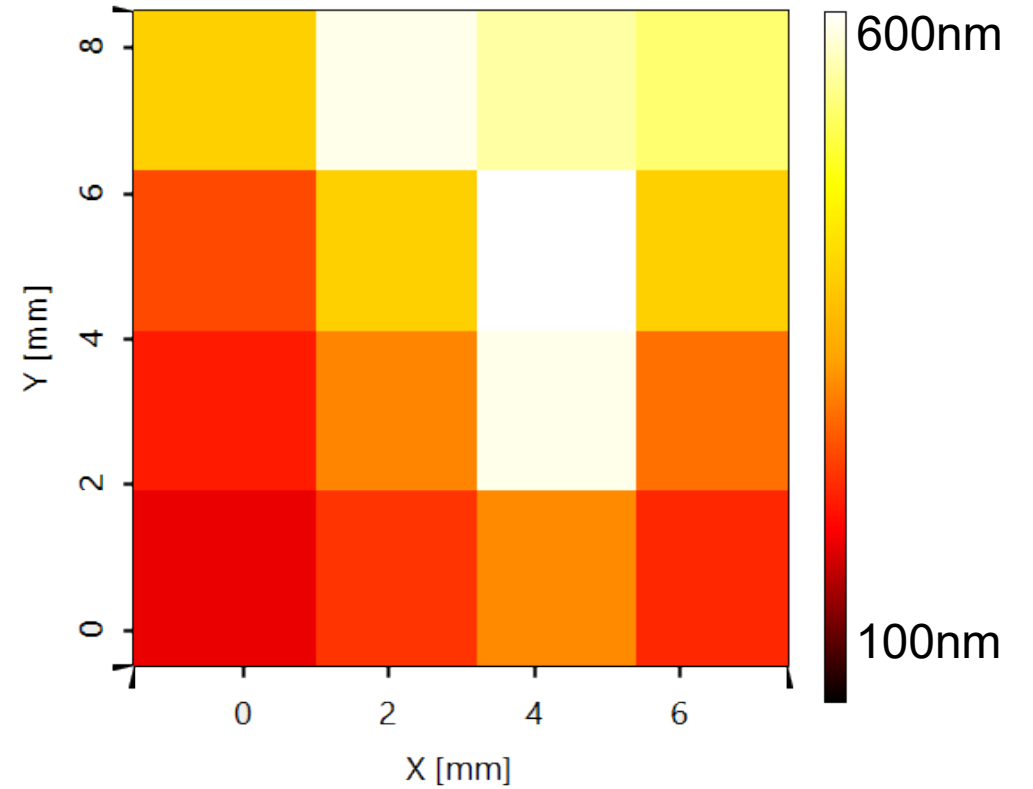

Optimized Modulation Depth

Grating Design for FOV Angle (5°, 3°)

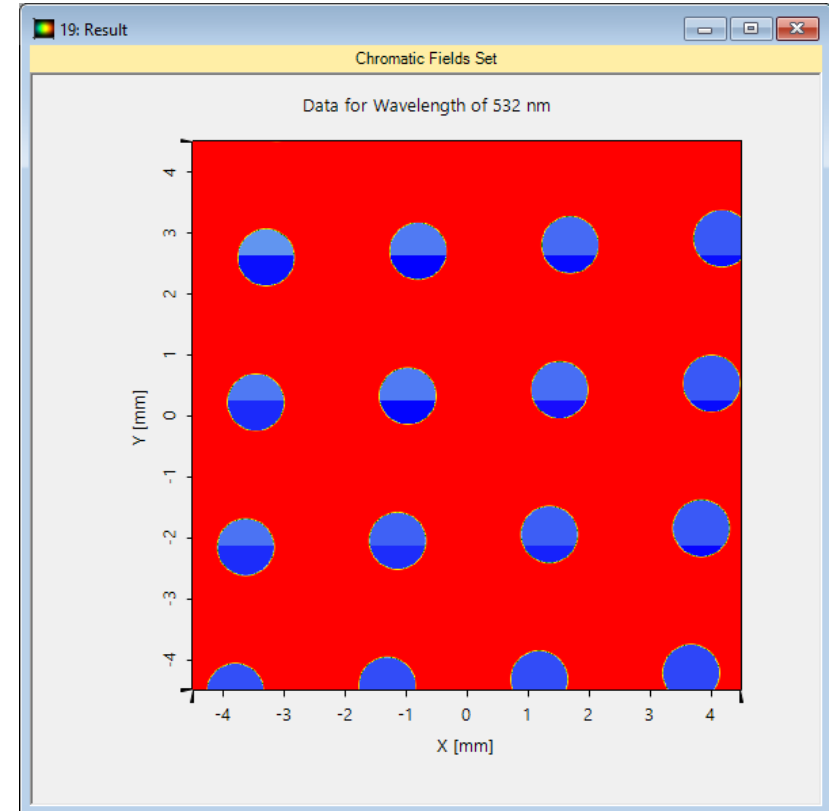
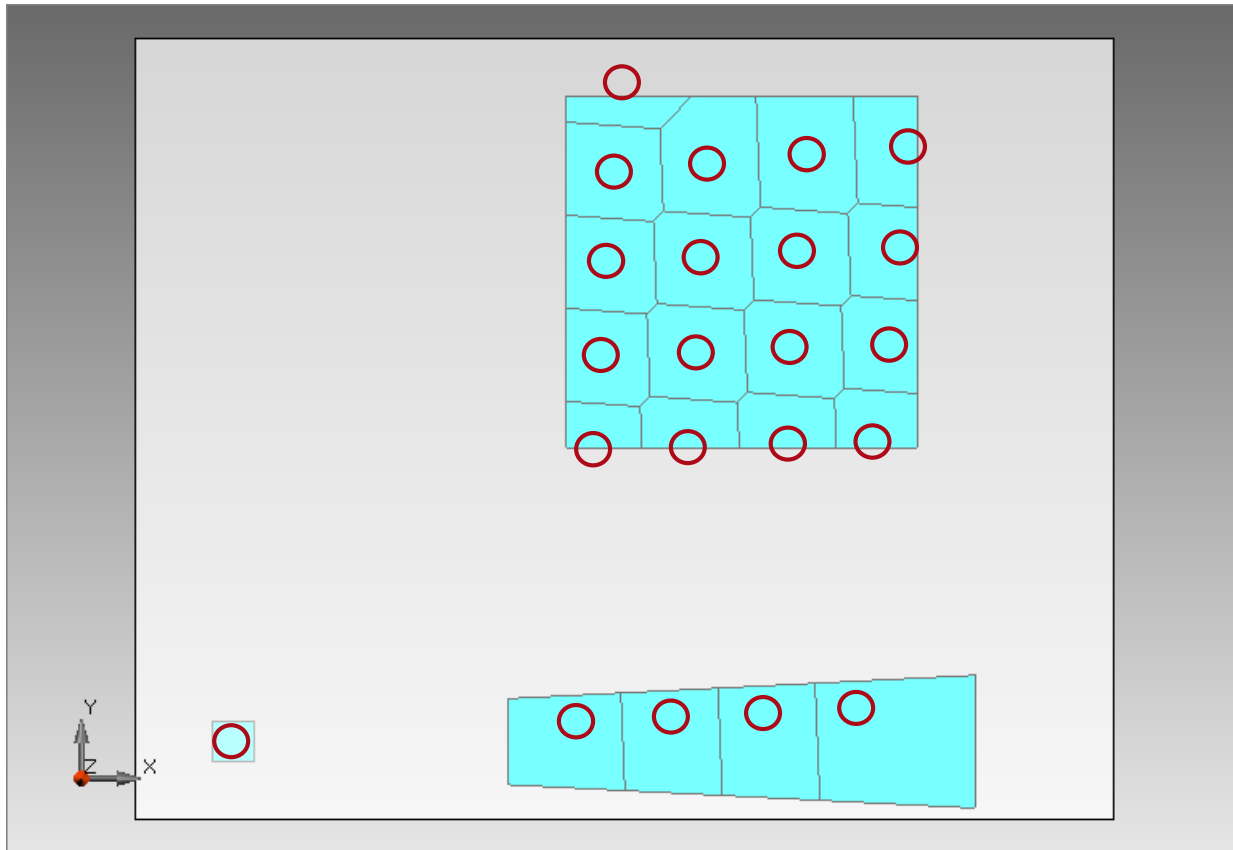

Merit Function	Value
----------------	-------

FOV Angle	$\alpha = 5^\circ; \beta = 3^\circ$
-----------	-------------------------------------

Uniformity Error	0.61%
------------------	--------------

Optimized Grating Parameter EPE Grating

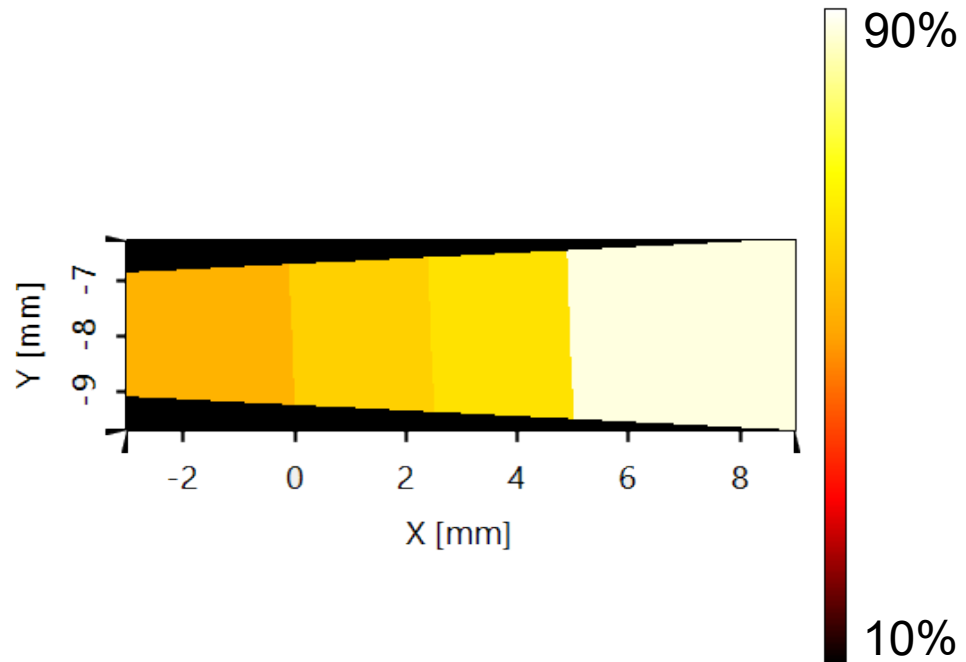

Optimized Fill Factors

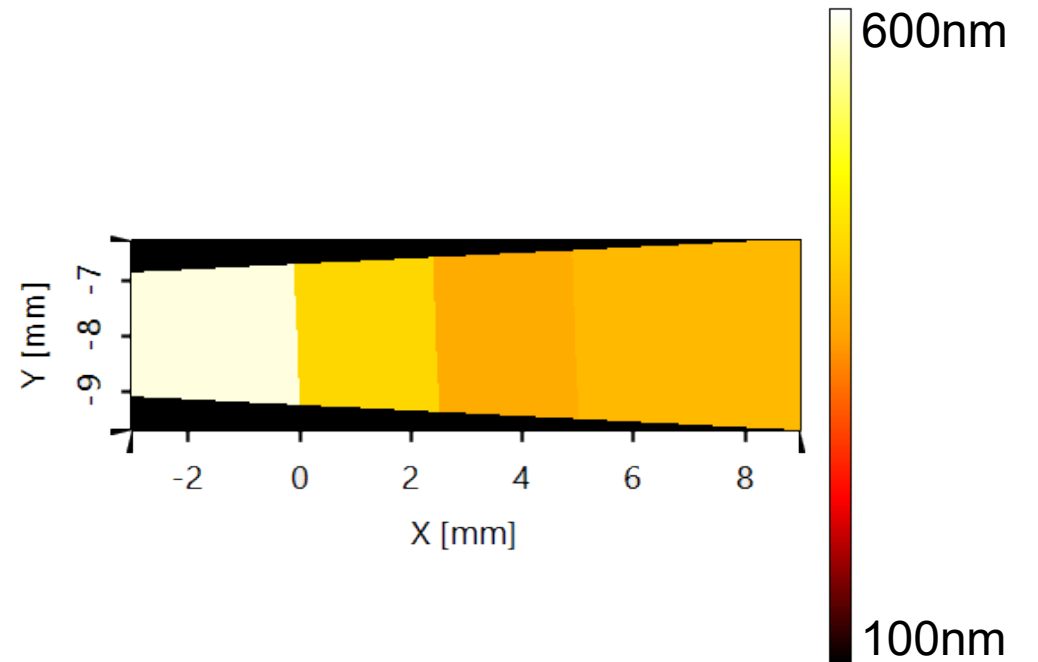

Optimized Modulation Depth

Optimized Grating Parameter Outcoupling Grating

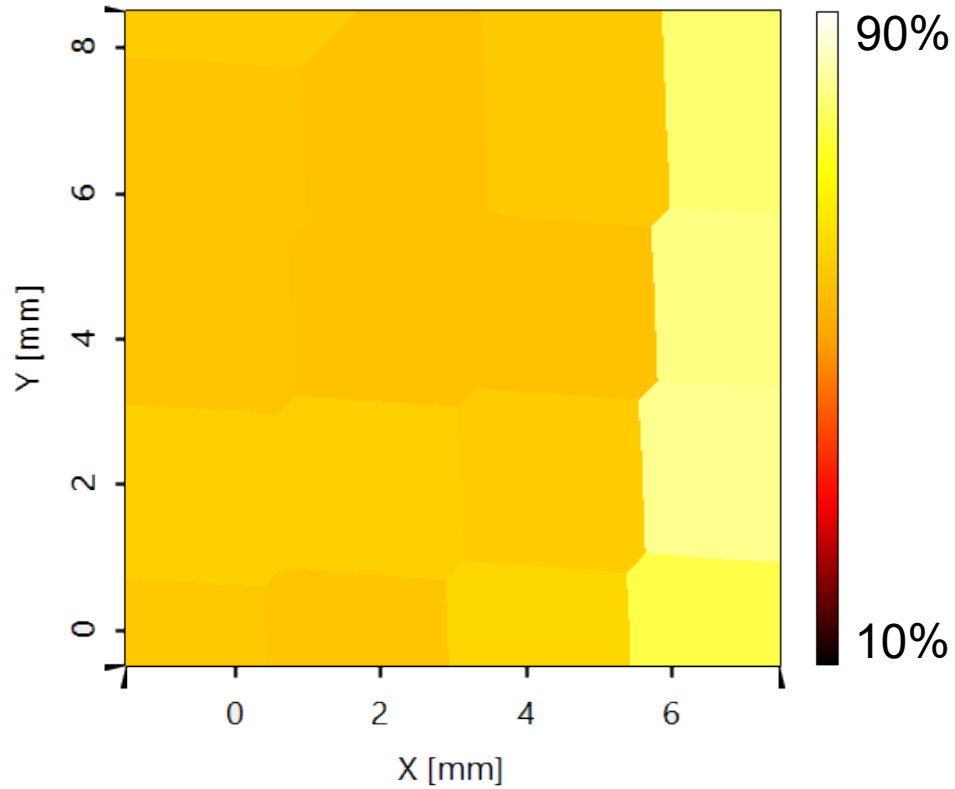

Optimized Fill Factors

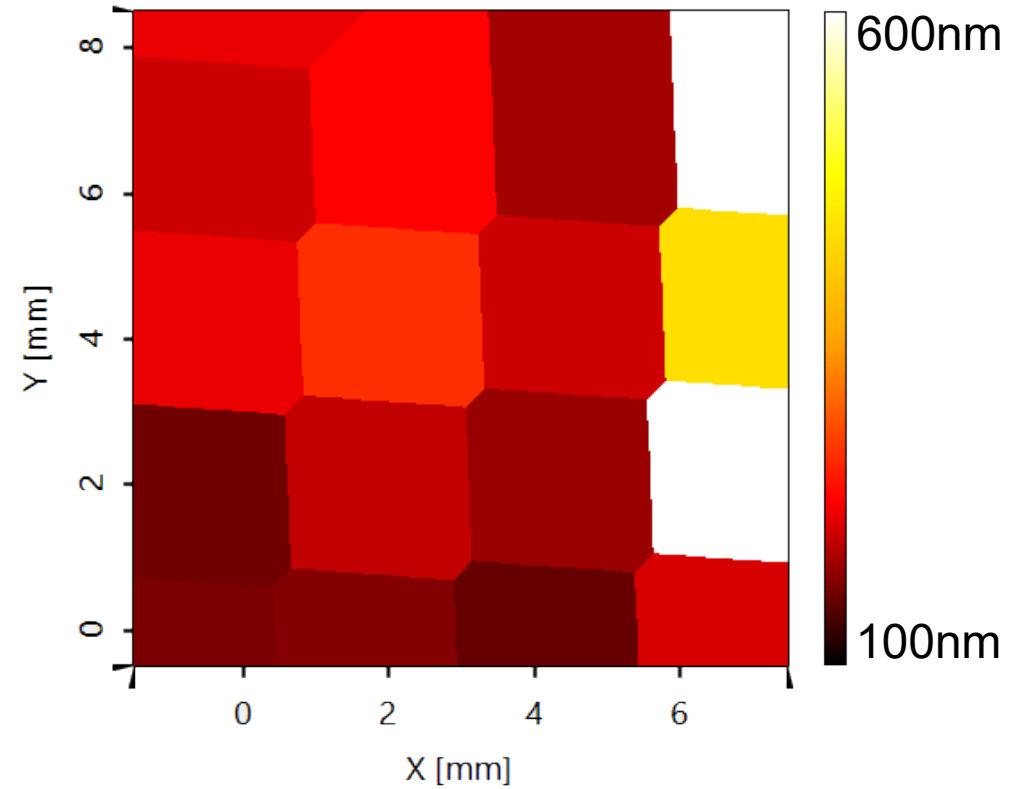

Optimized Modulation Depth

Grating Design for FOV Angle (6°, -2.5°)

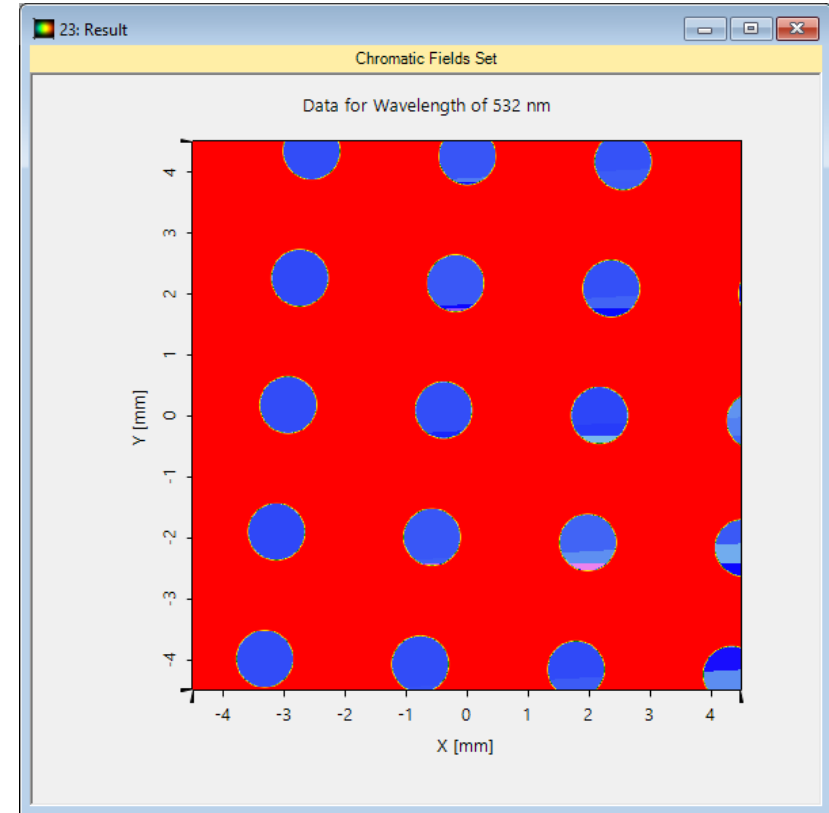
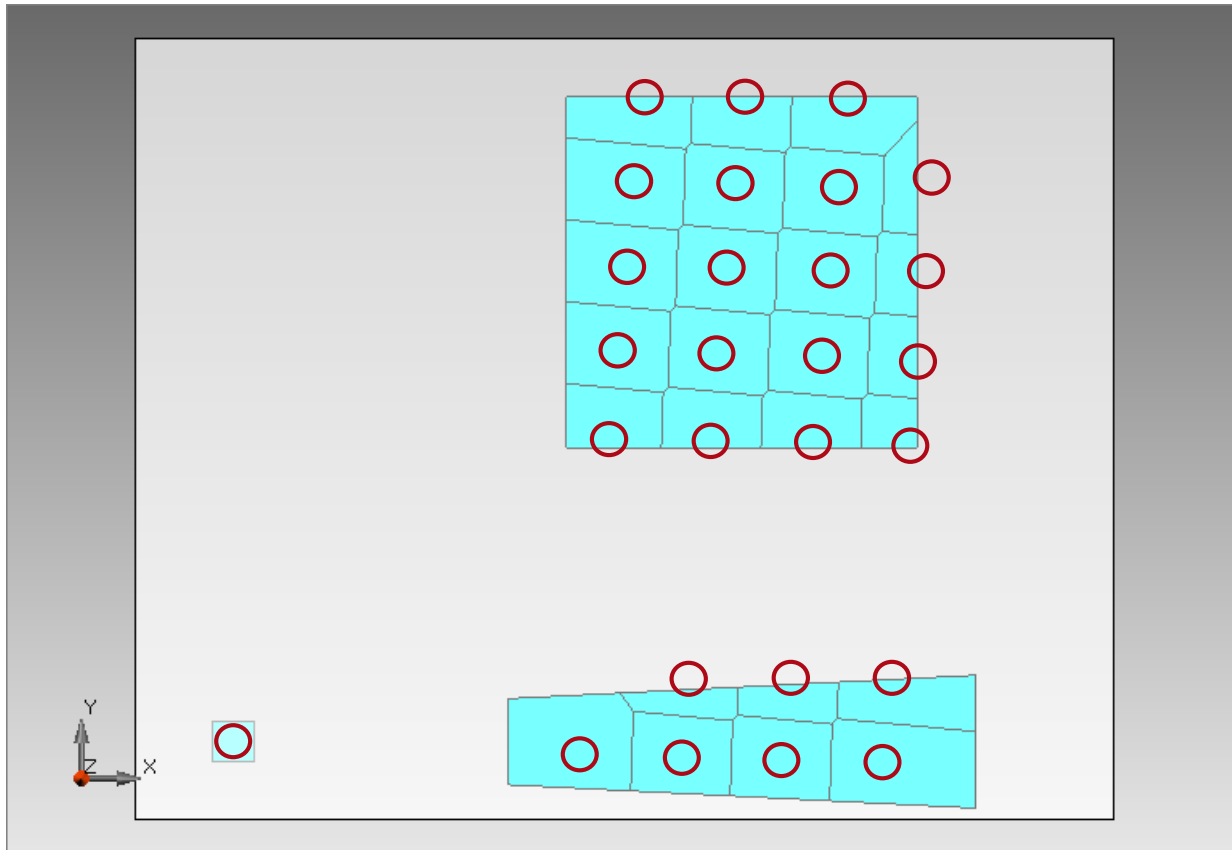

Merit Function	Value
FOV Angle	$\alpha = 6^\circ; \beta = -2.5^\circ$
Uniformity Error	1.32%

Optimized Grating Parameter EPE Grating

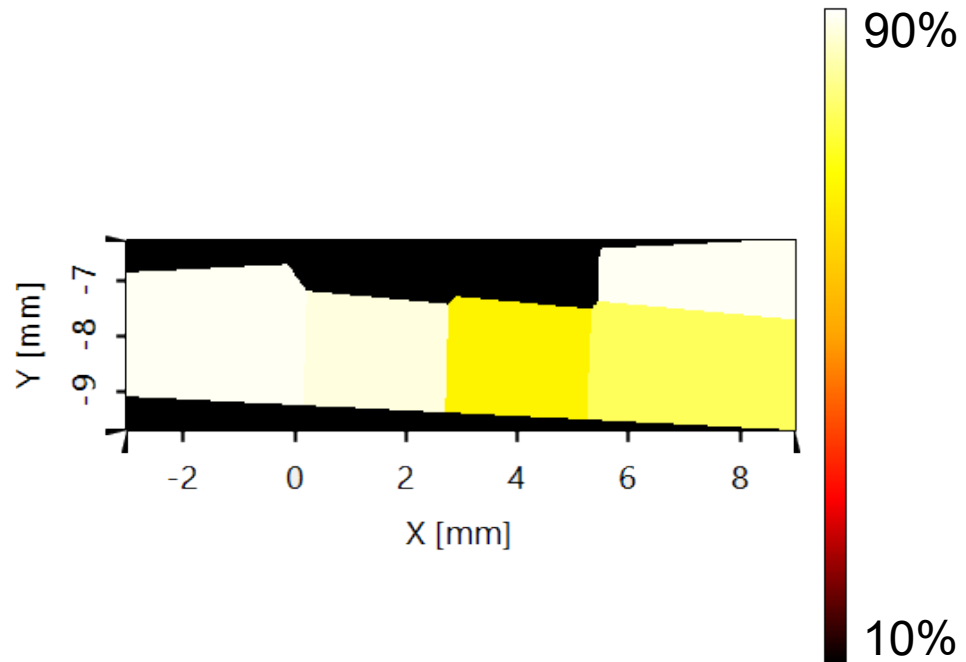

Optimized Fill Factors

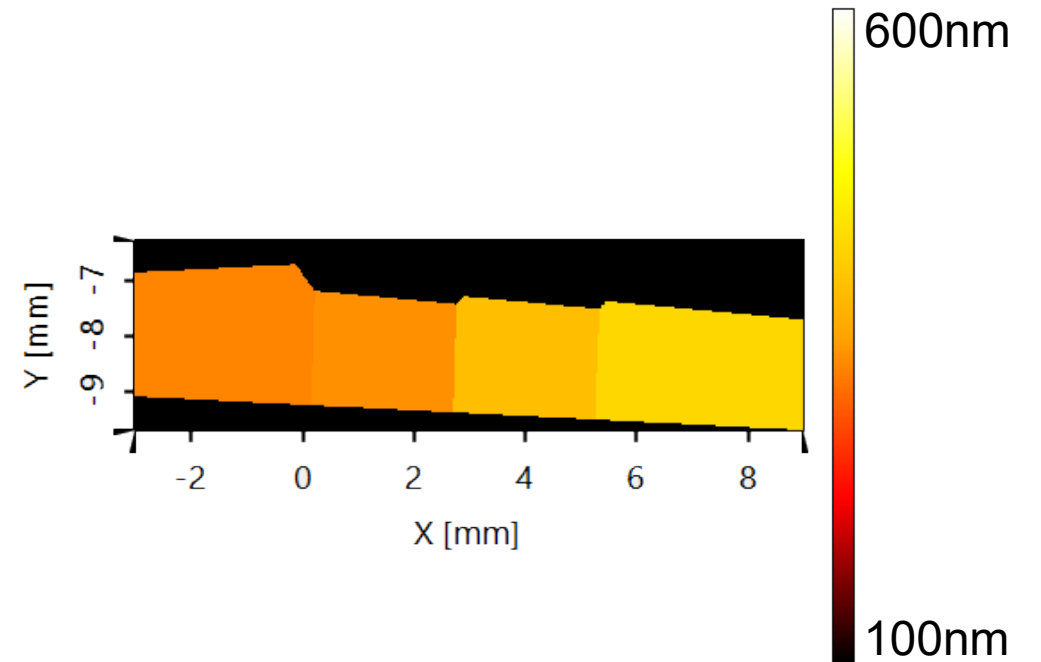

Optimized Modulation Depth

Optimized Grating Parameter Outcoupling Grating

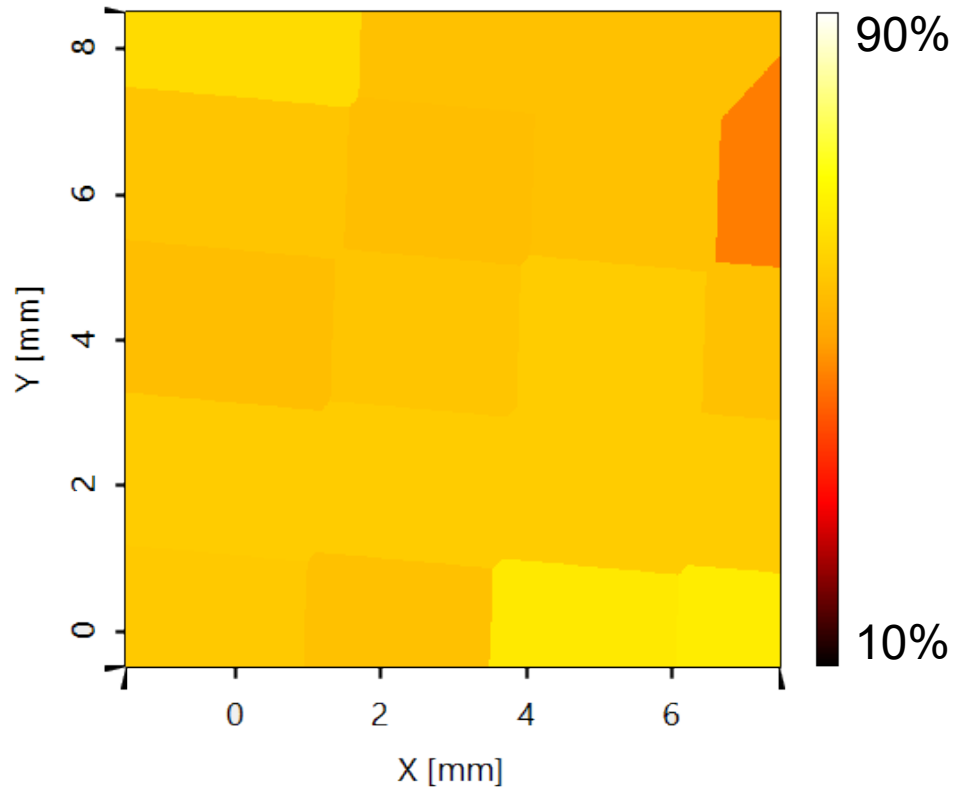

Optimized Fill Factors

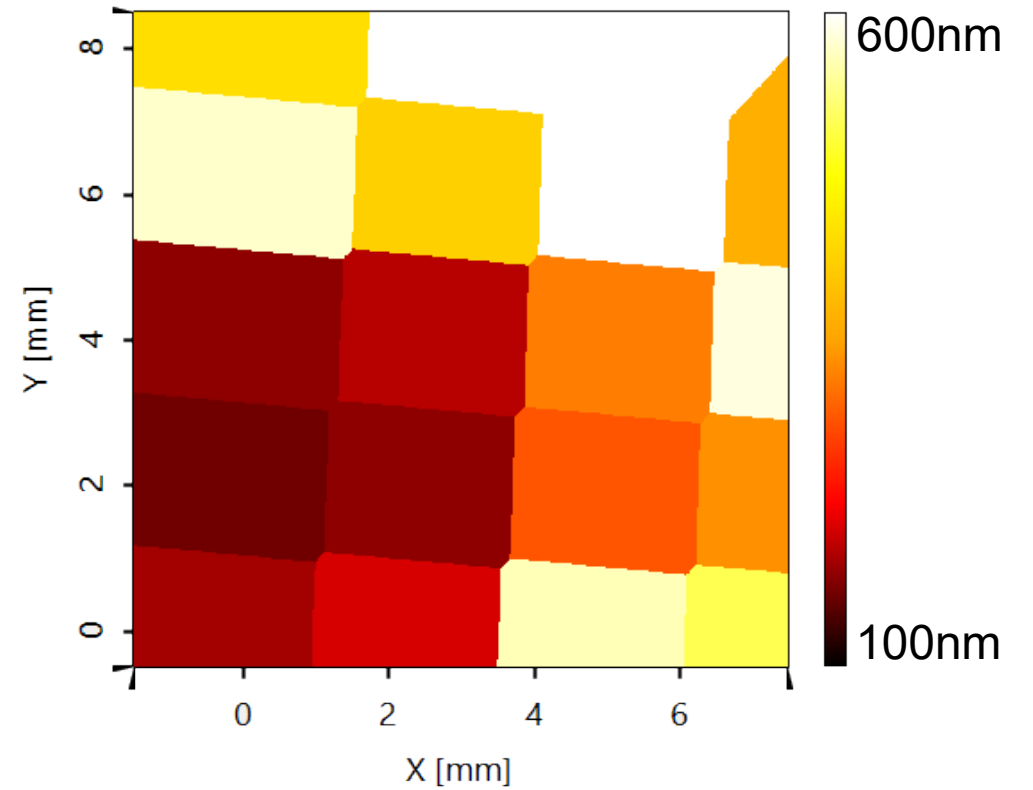

Optimized Modulation Depth

Grating Design for FOV Angle (-6°, -3°)

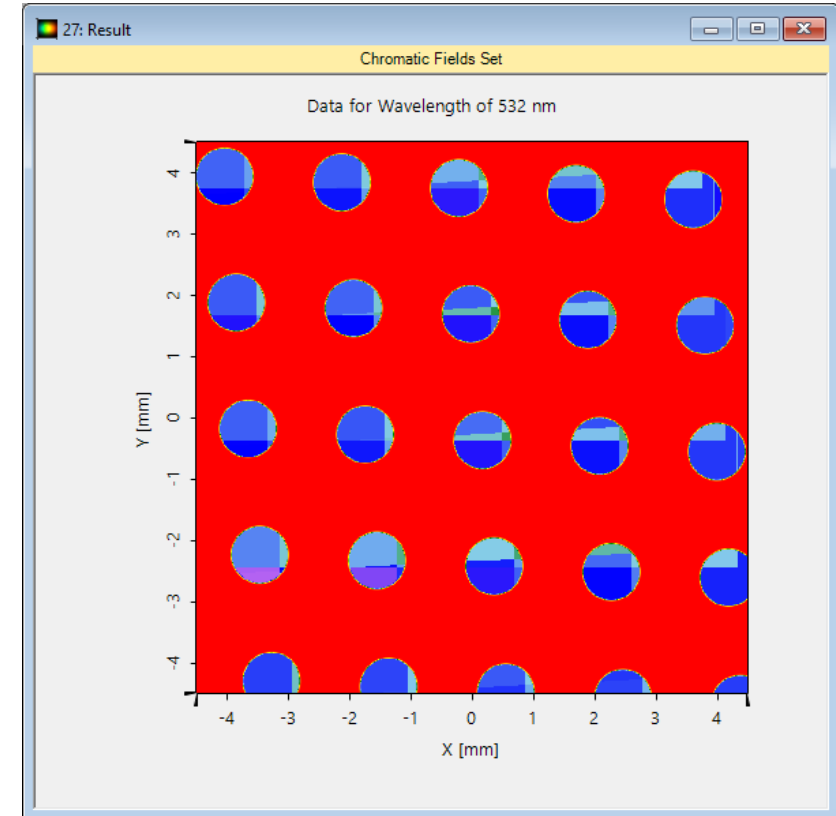
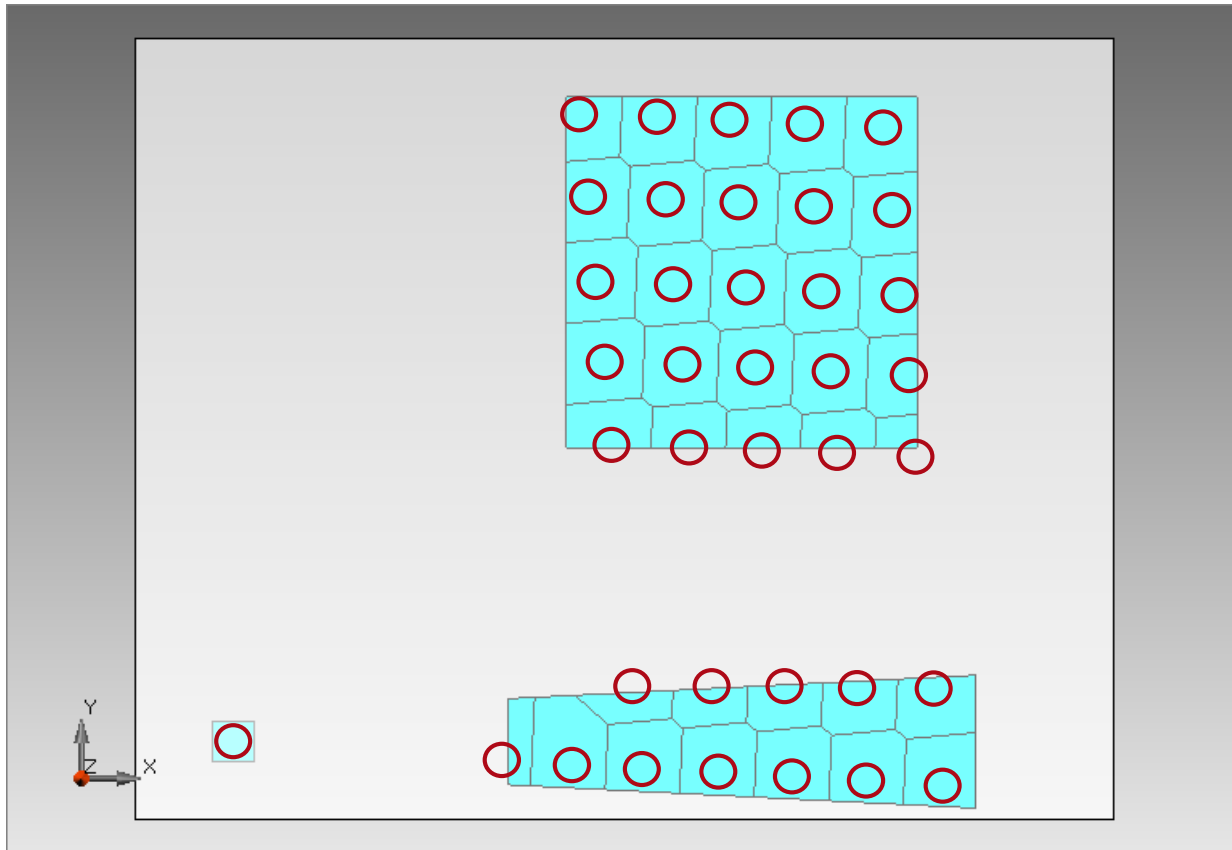

Merit Function	Value
----------------	-------

FOV Angle	$\alpha = -6^\circ; \beta = -3^\circ$
-----------	---------------------------------------

Uniformity Error	1.14%
------------------	--------------

Optimized Grating Parameter EPE Grating

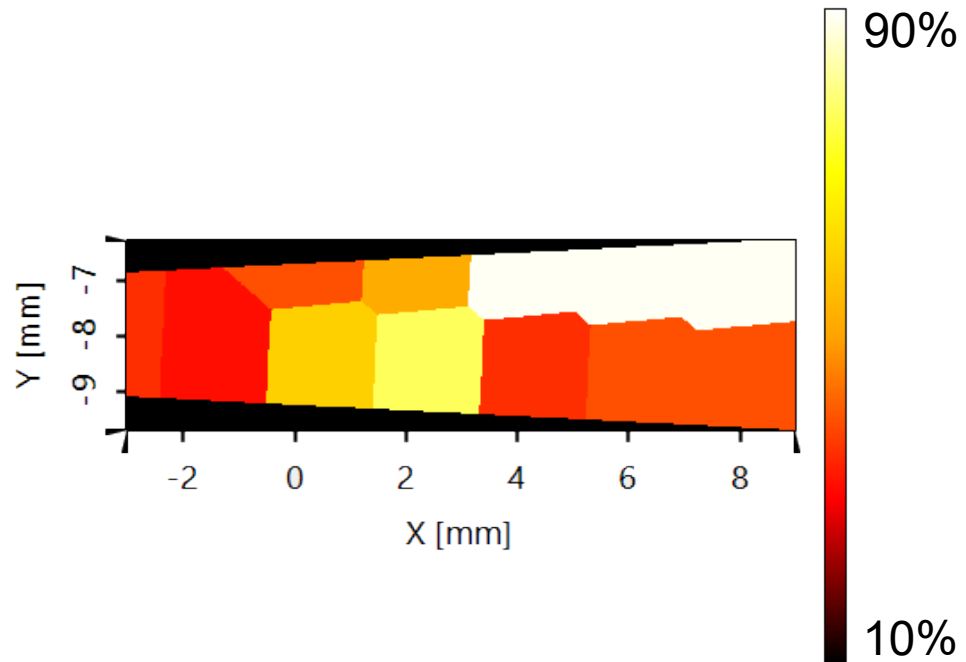

Optimized Fill Factors

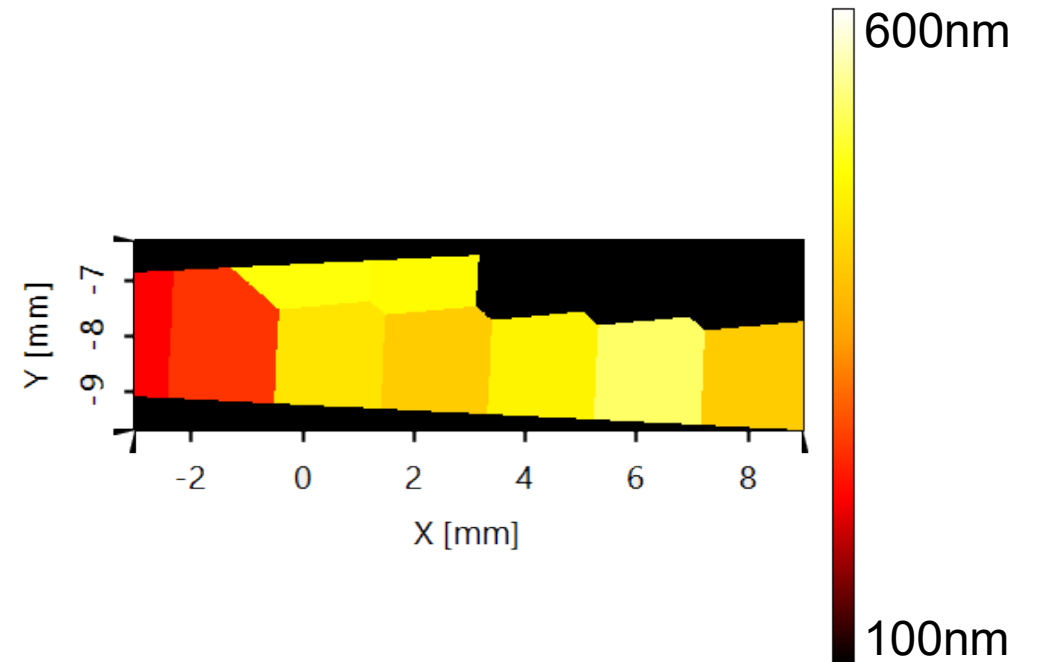

Optimized Modulation Depth

Optimized Grating Parameter Outcoupling Grating

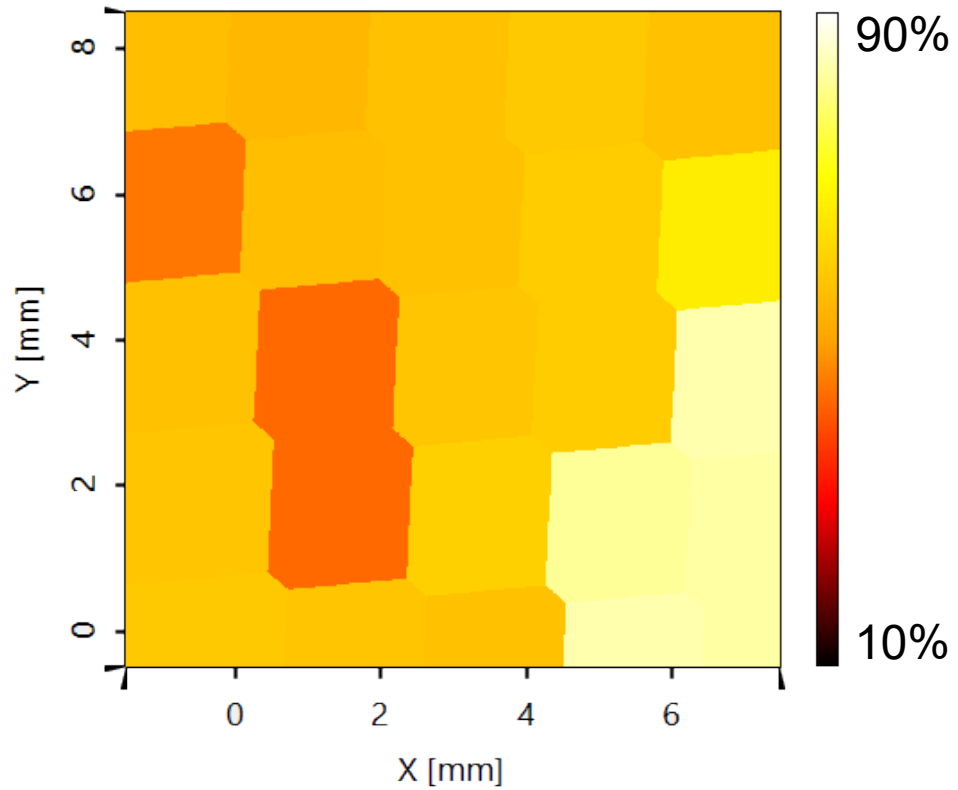

Optimized Fill Factors

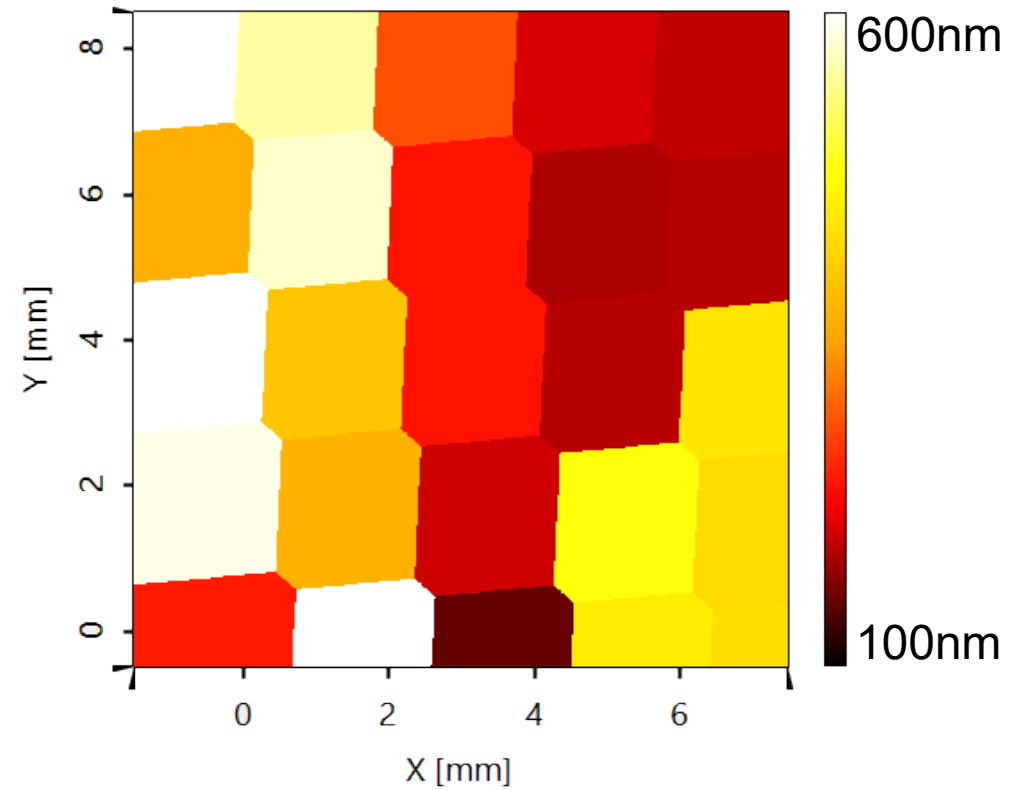

Optimized Modulation Depth

Grating Design for FOV Angle (-7°, 2°)

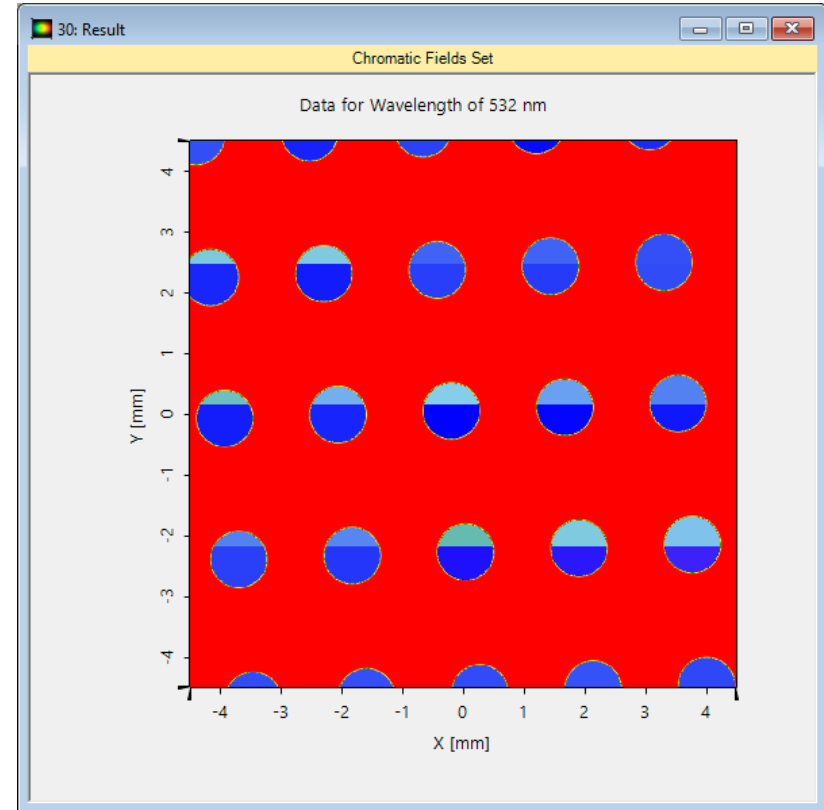
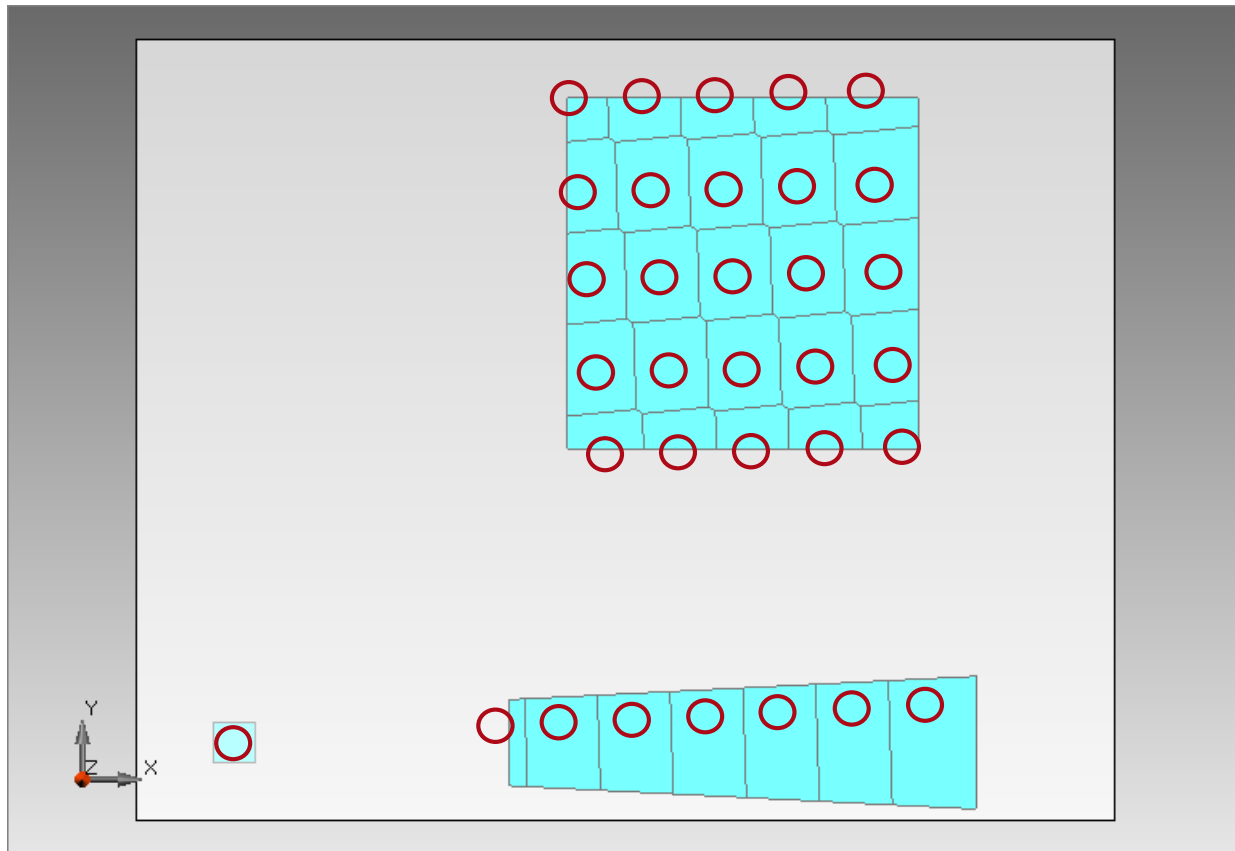

Merit Function	Value
----------------	-------

FOV Angle	$\alpha = -7^\circ; \beta = 2^\circ$
-----------	--------------------------------------

Uniformity Error	0.72%
------------------	--------------

Optimized Grating Parameter EPE Grating

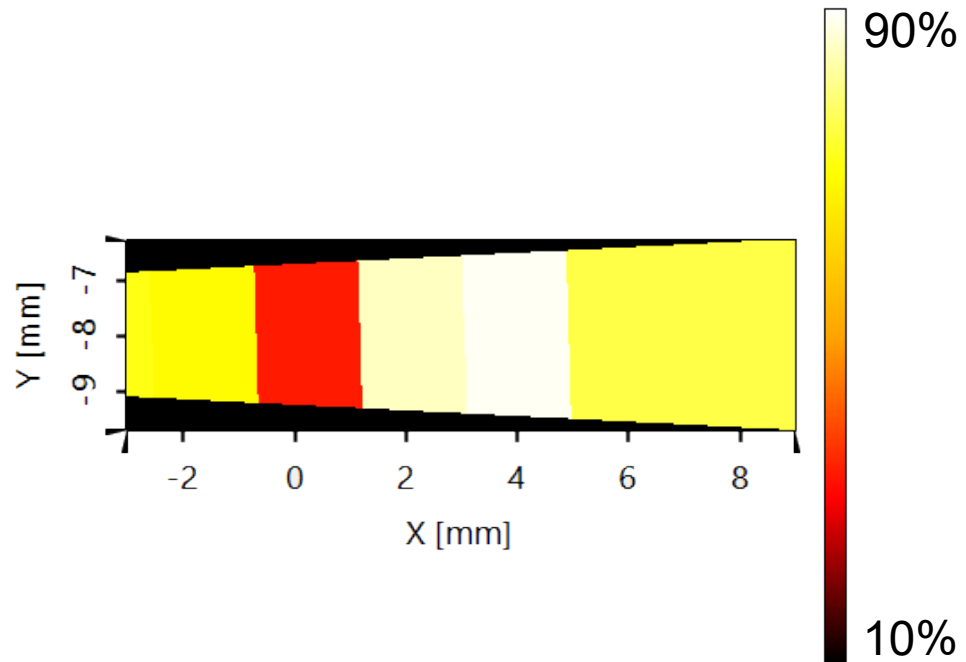

Optimized Fill Factors

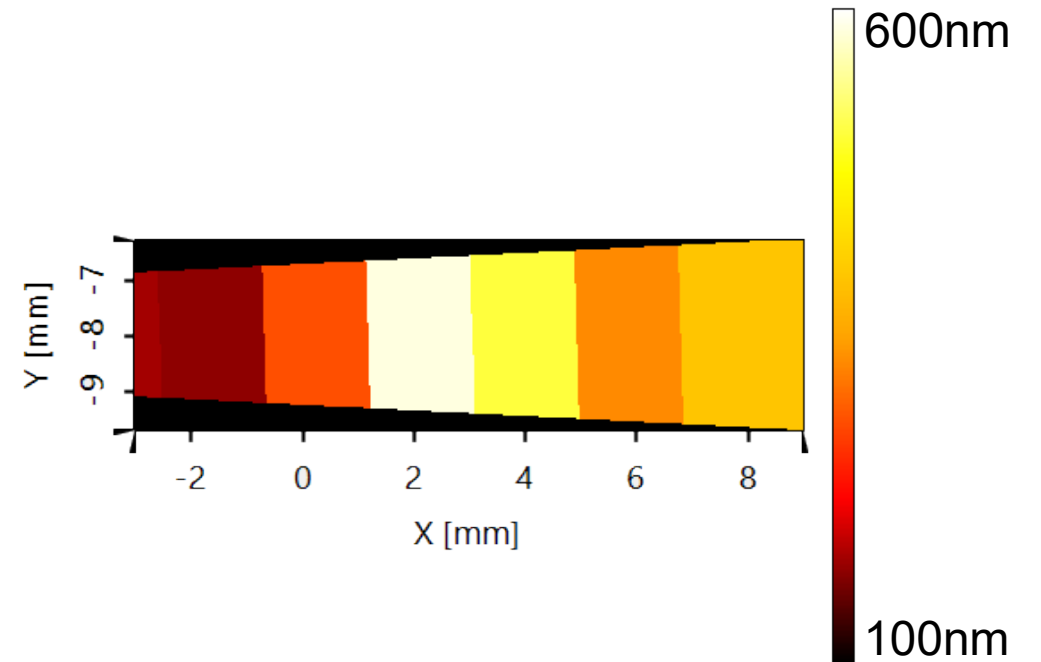

Optimized Modulation Depth

Optimized Grating Parameter Outcoupling Grating

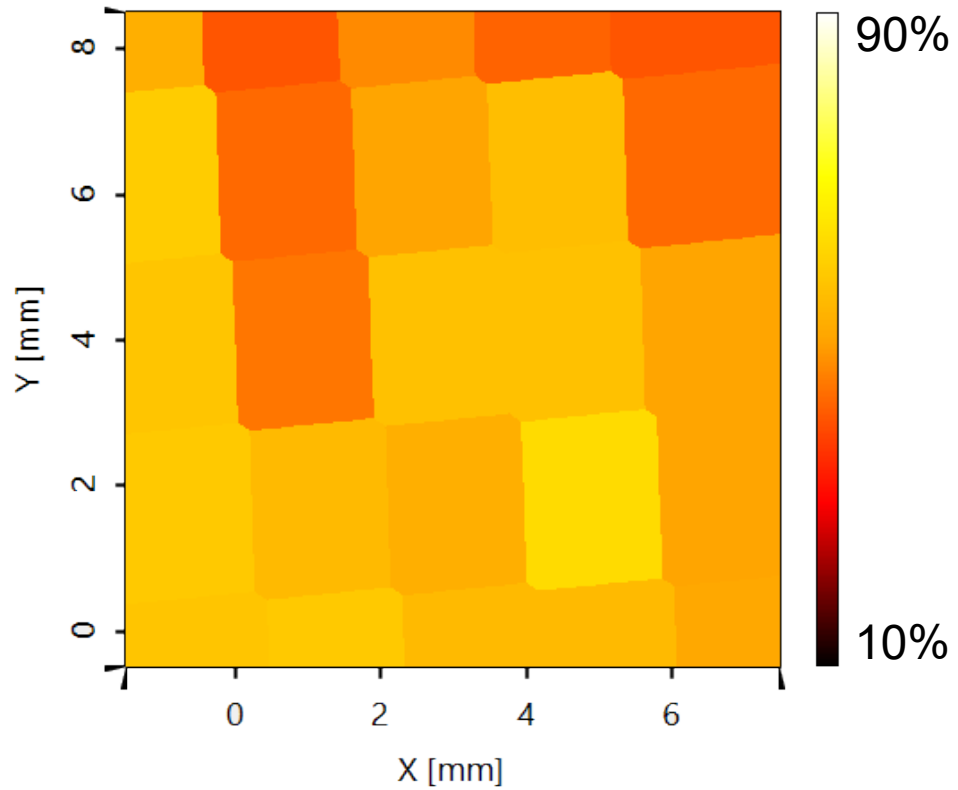

Optimized Fill Factors

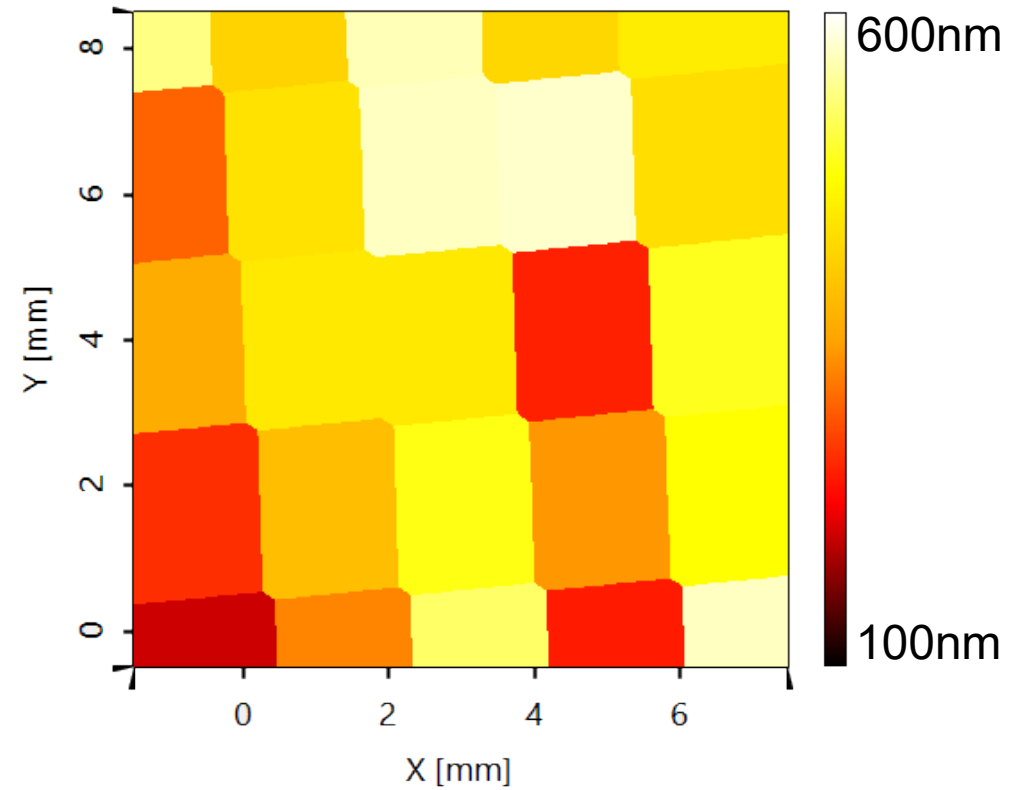

Optimized Modulation Depth

EPE Grating Design for Different FOV: Height

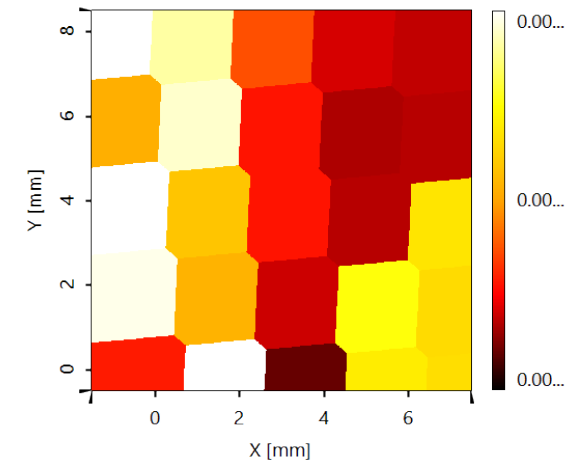
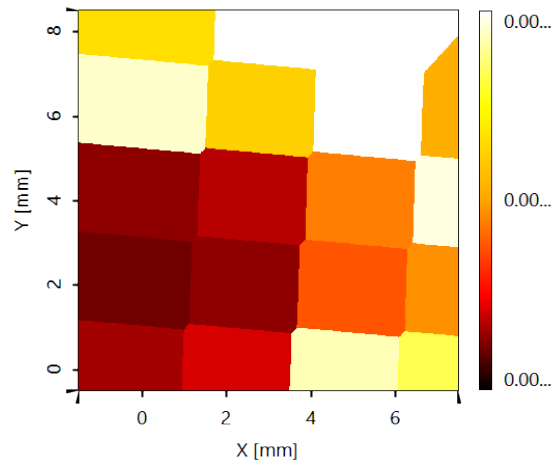
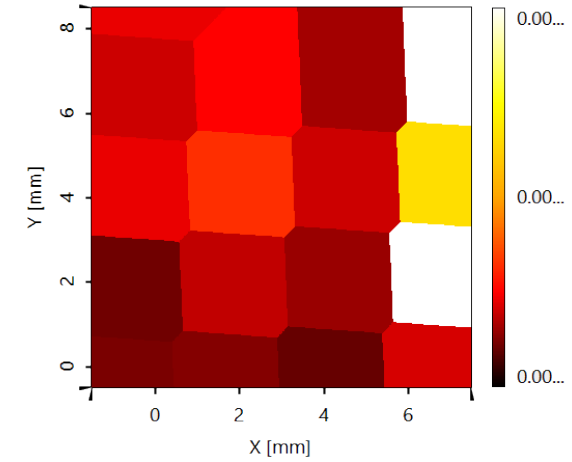
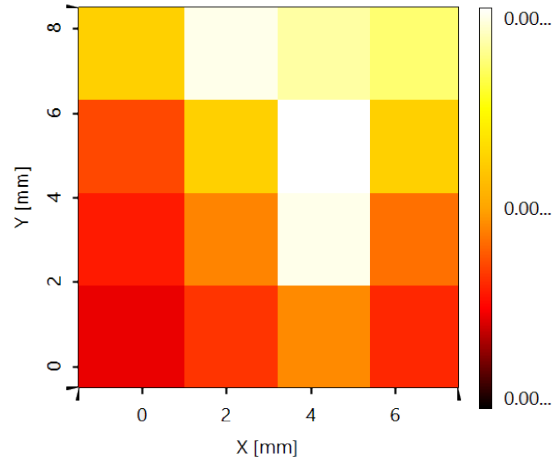

Lightguide Modeling and Design: Grating Optimization

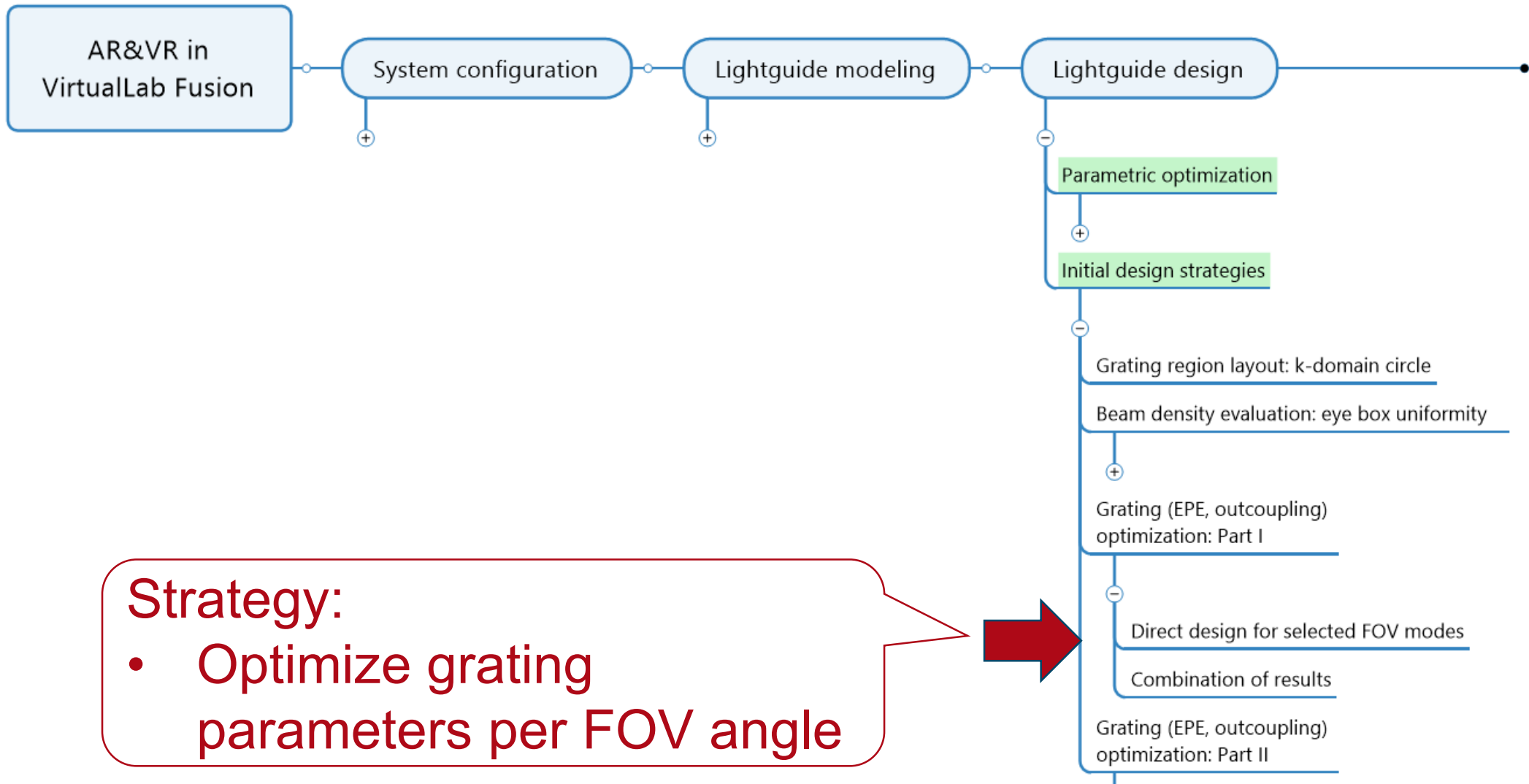

Lightguide Modeling and Design: Grating Optimization

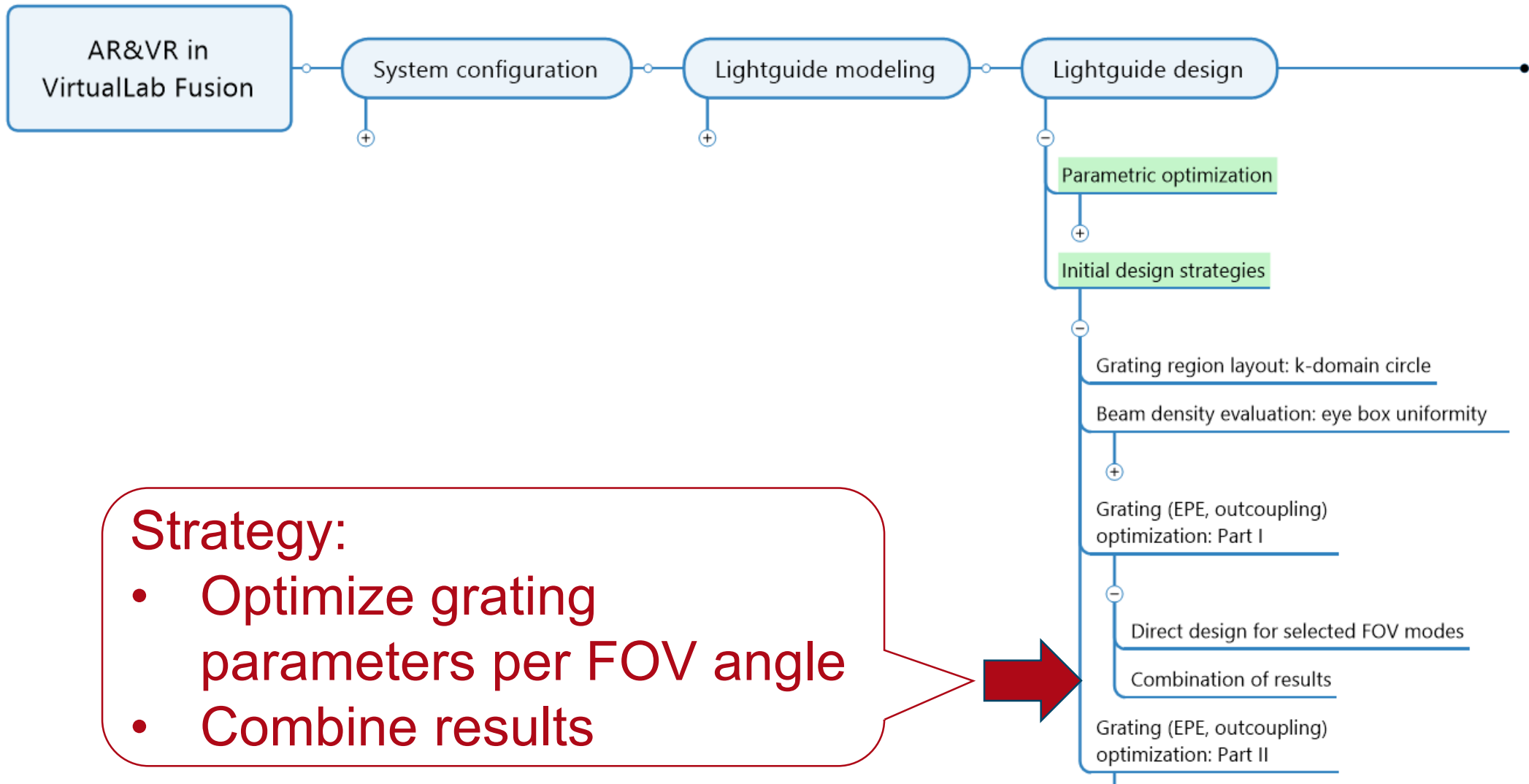

Combination of Different FOV Designs

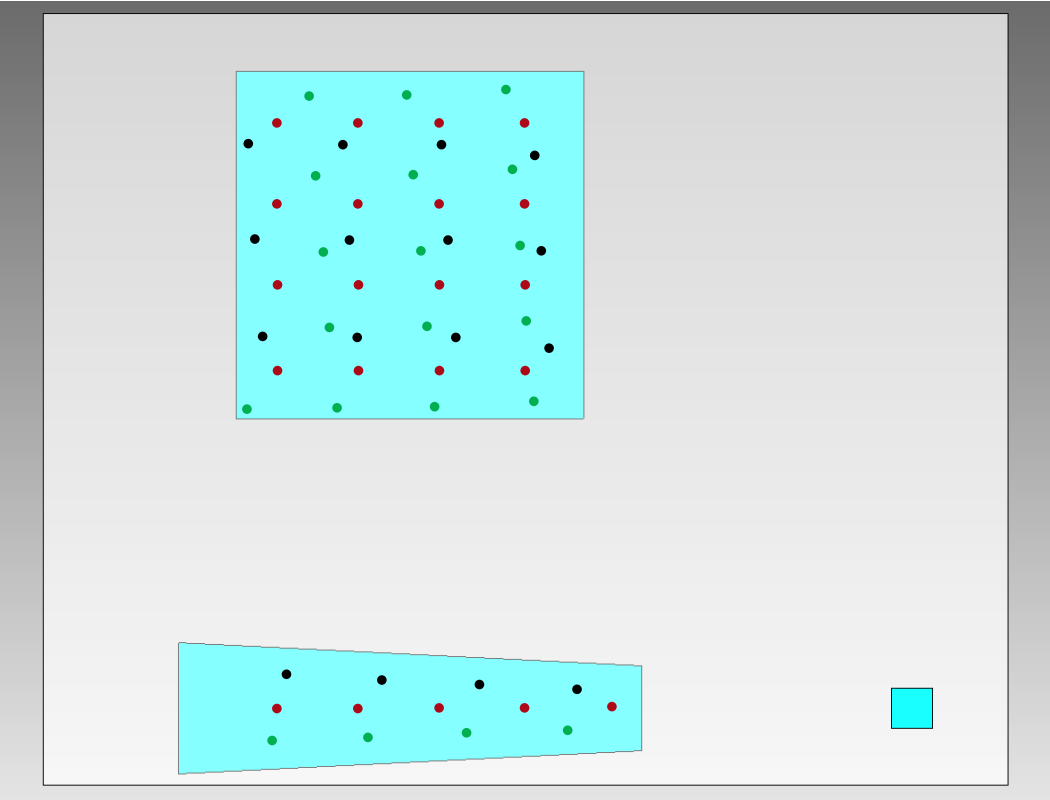

+

Voronoi Segmentation

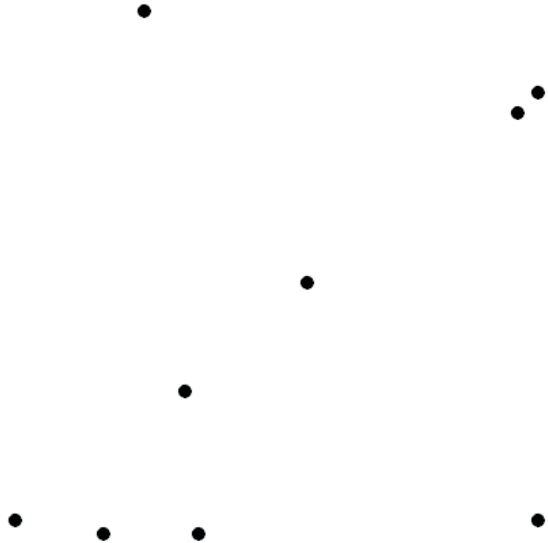

Source: www.wikipedia.com

Combination of Different FOV Designs

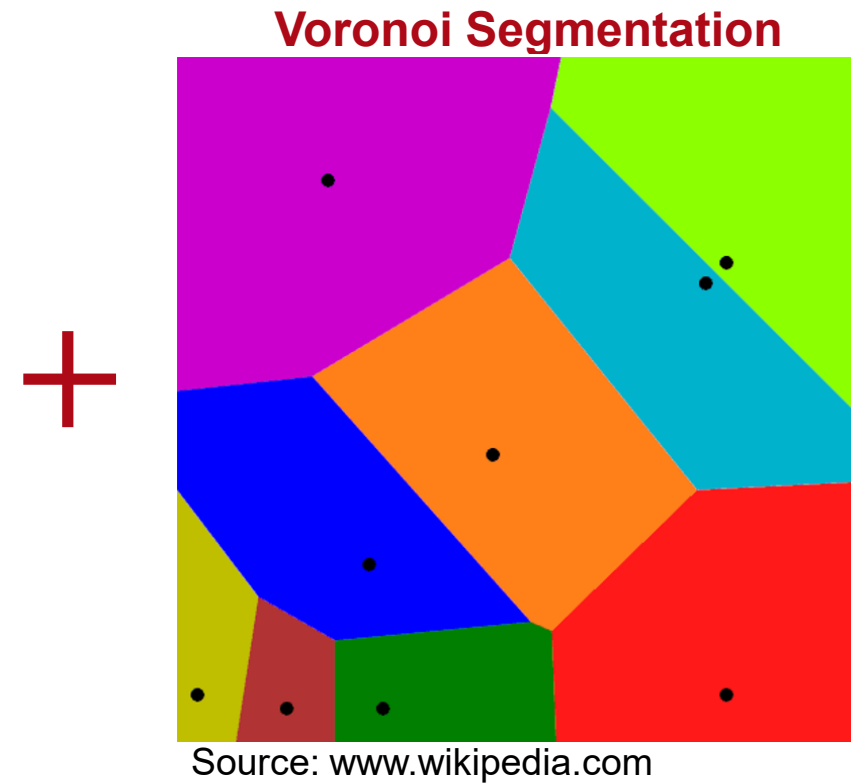
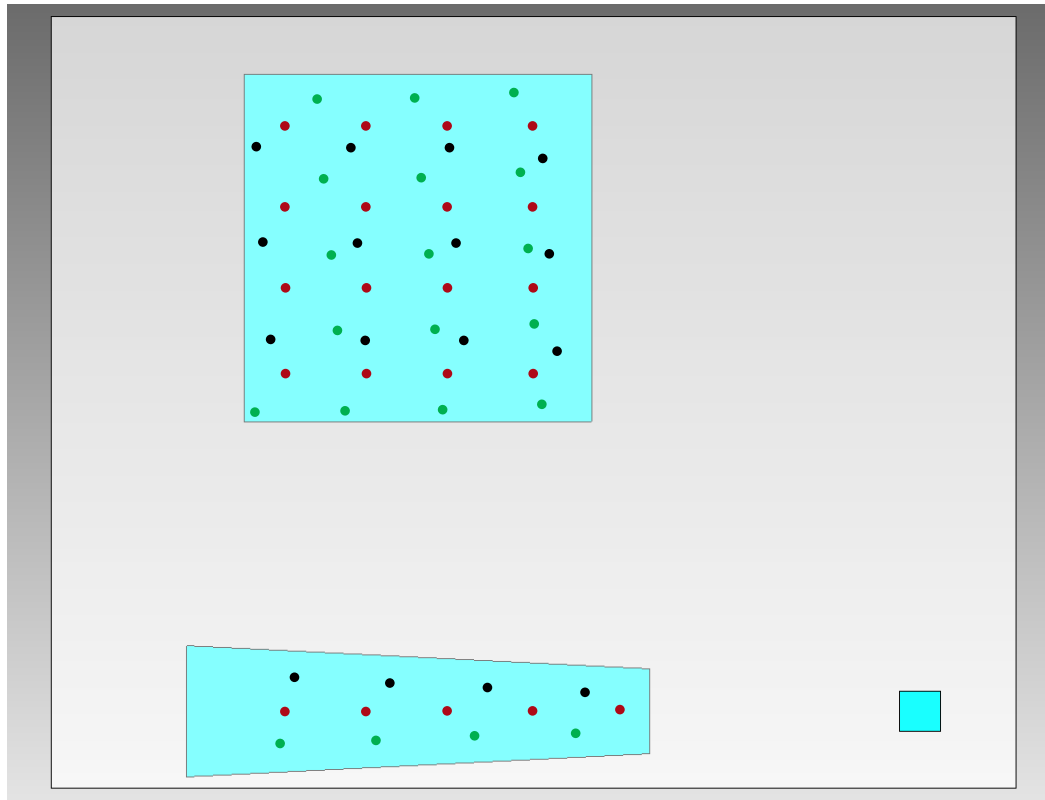

Optimized Grating Parameter EPE Grating

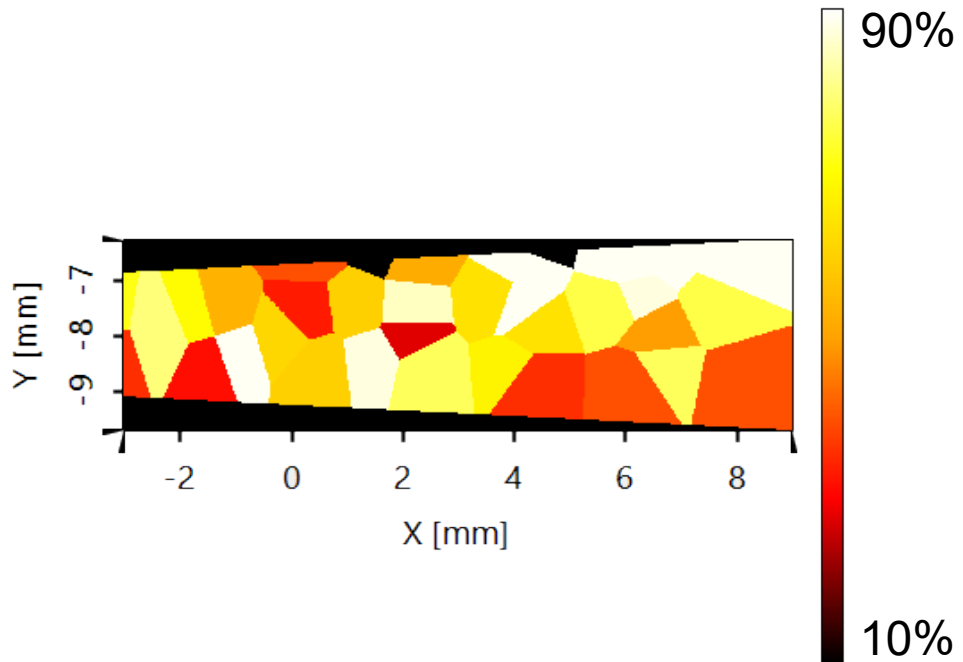

Optimized Fill Factors

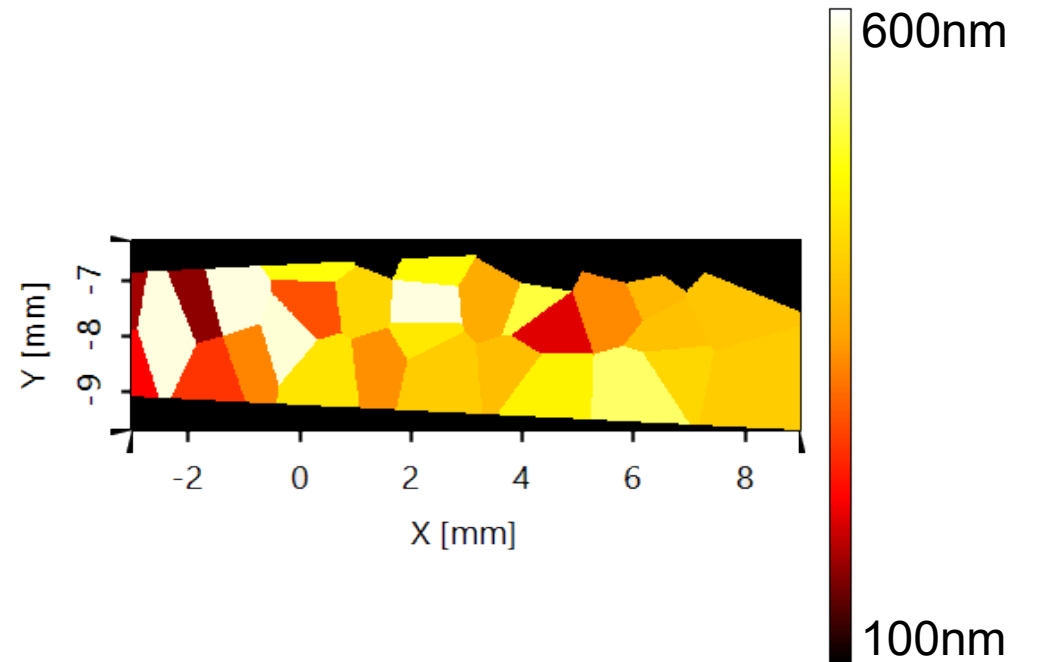

Optimized Modulation Depth

Optimized Grating Parameter Outcoupling Grating

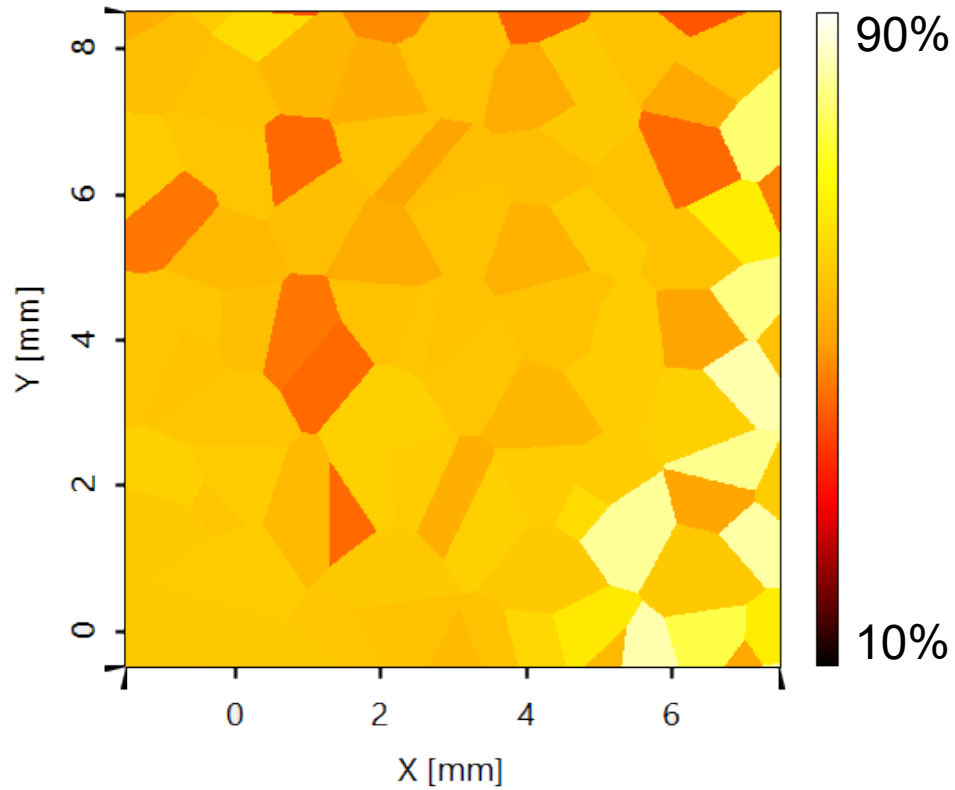

Optimized Fill Factors

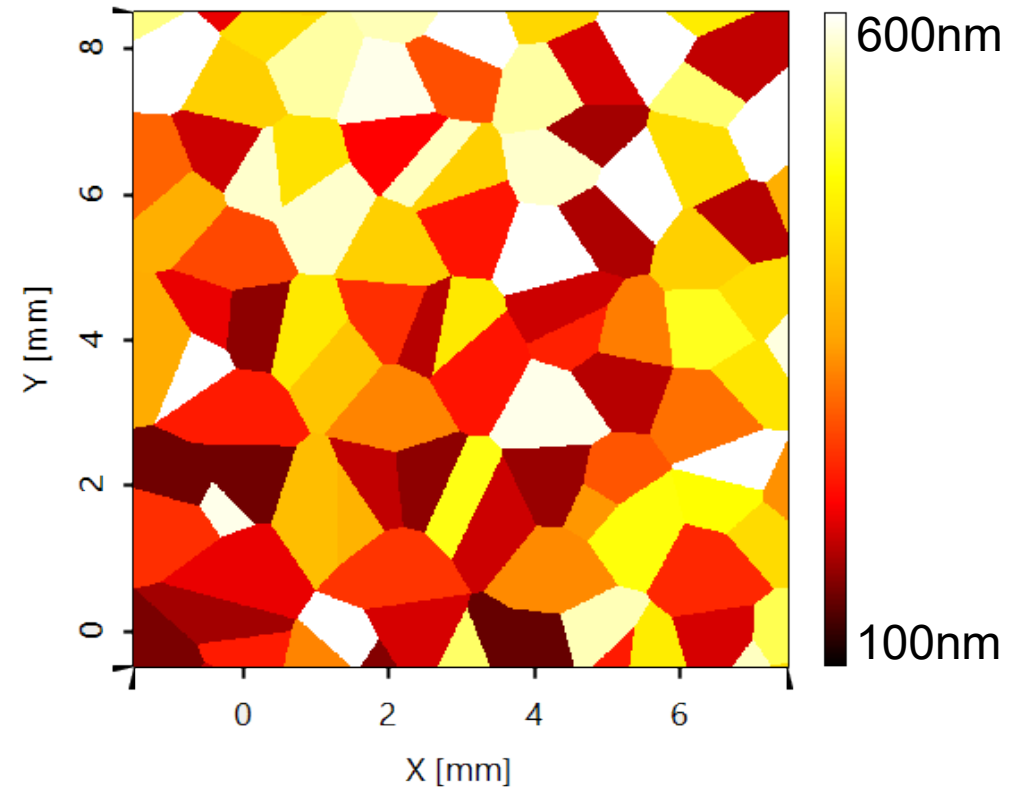

Optimized Modulation Depth

Result Combination of Modes (Segmentation)

Each color indicates segments, which were optimized for one mode.

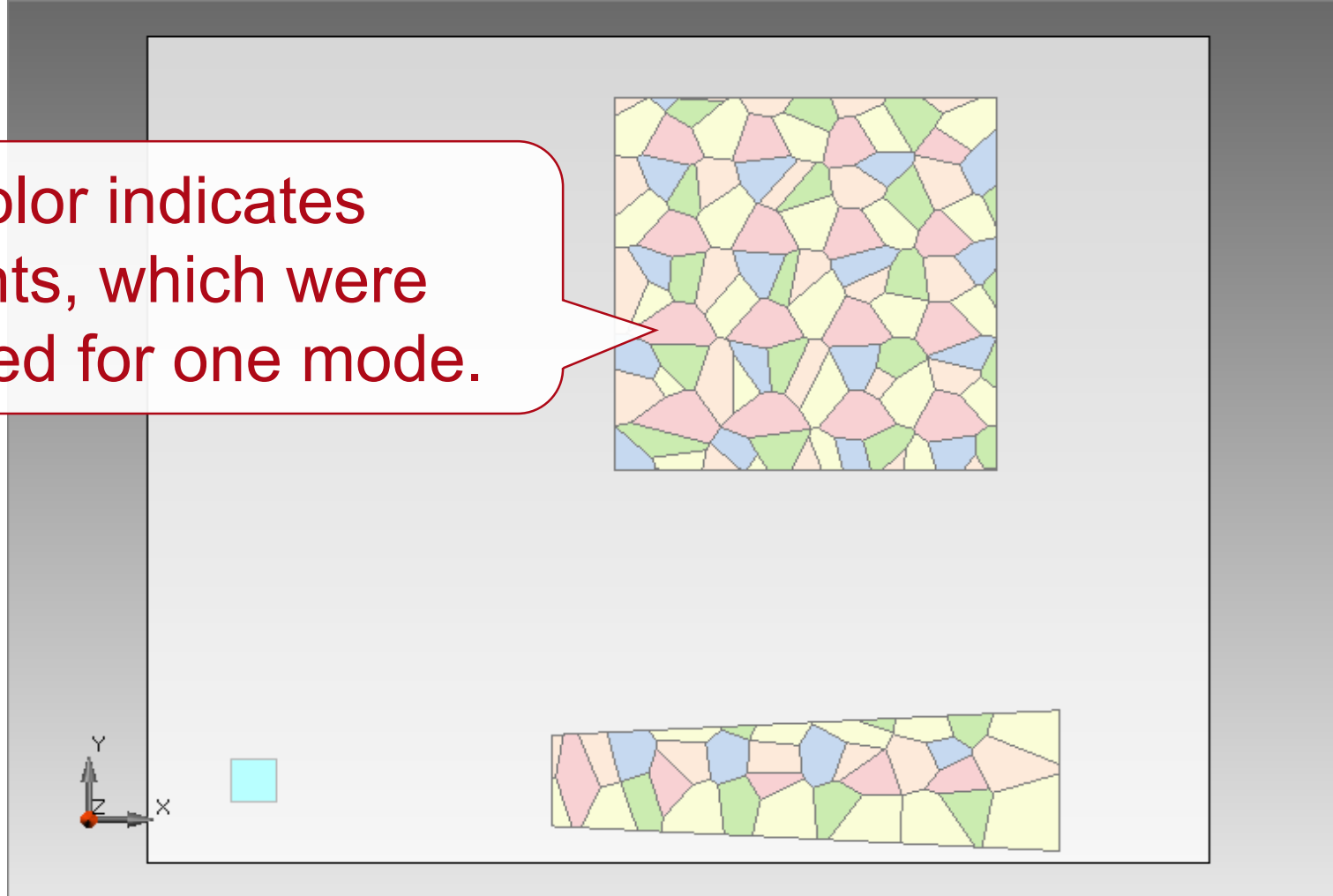

Result Combination of Modes (Segmentation)

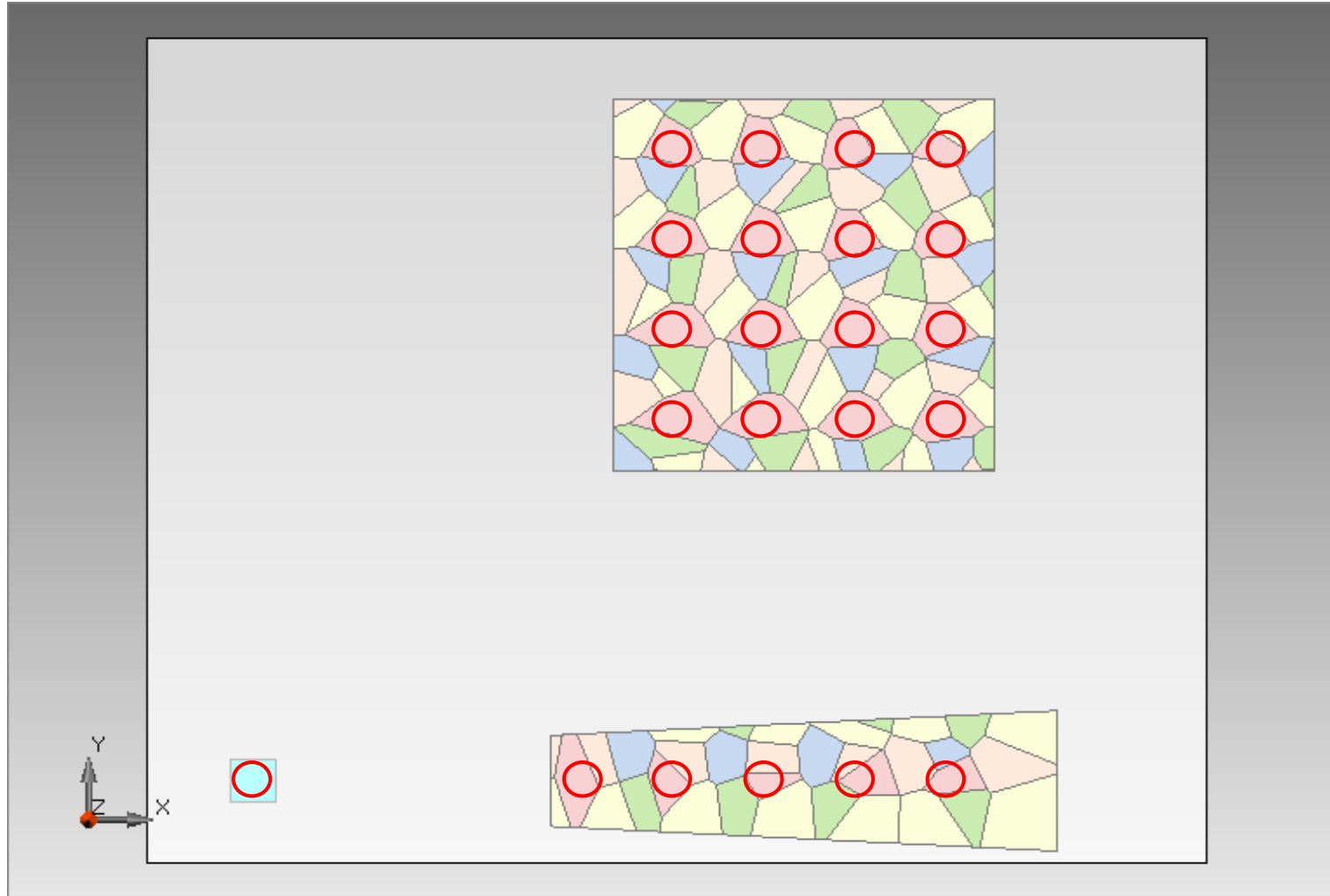

Result Combination of Modes (Segmentation)

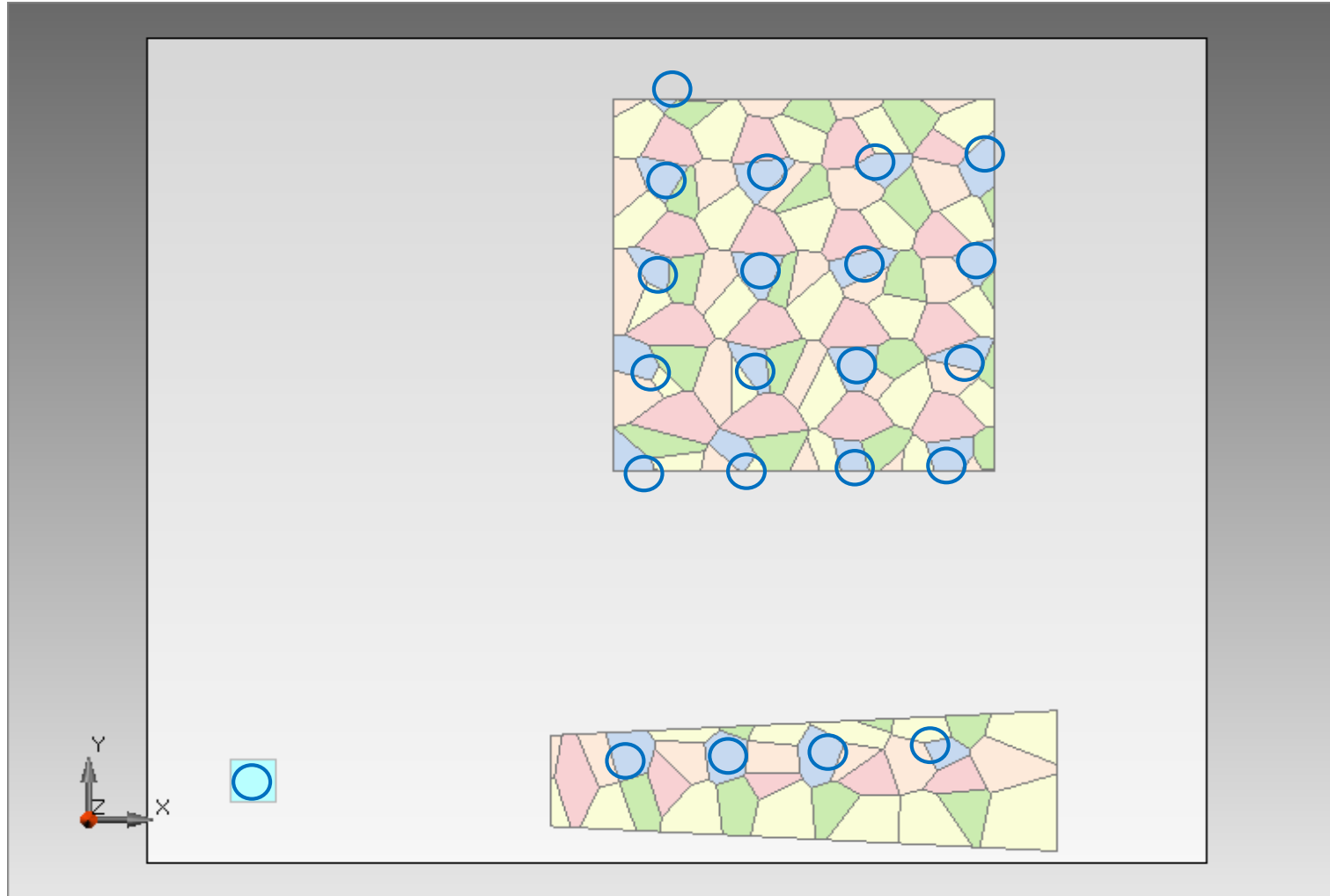

Result Combination of Modes (Segmentation)

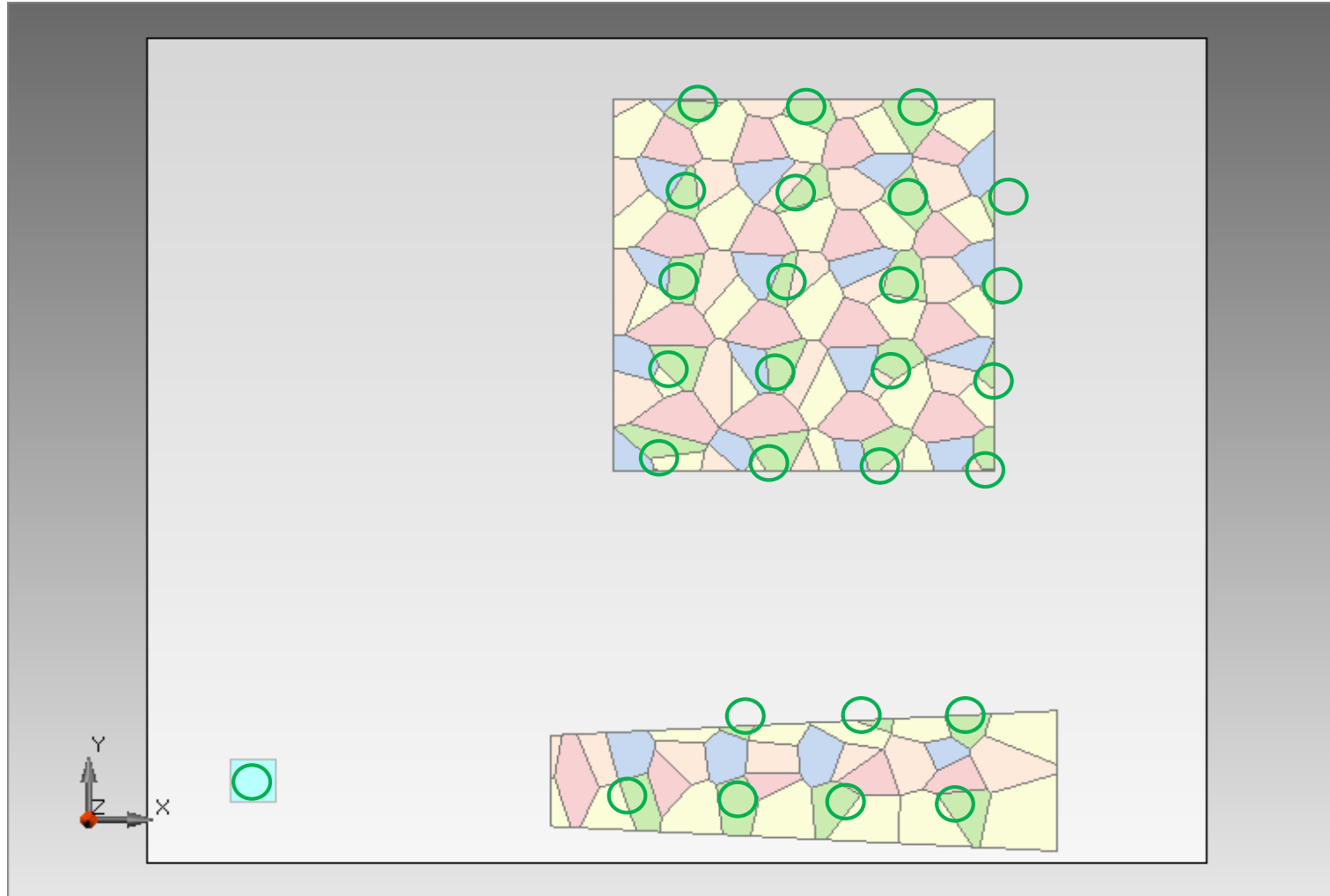

Result Combination of Modes (Segmentation)

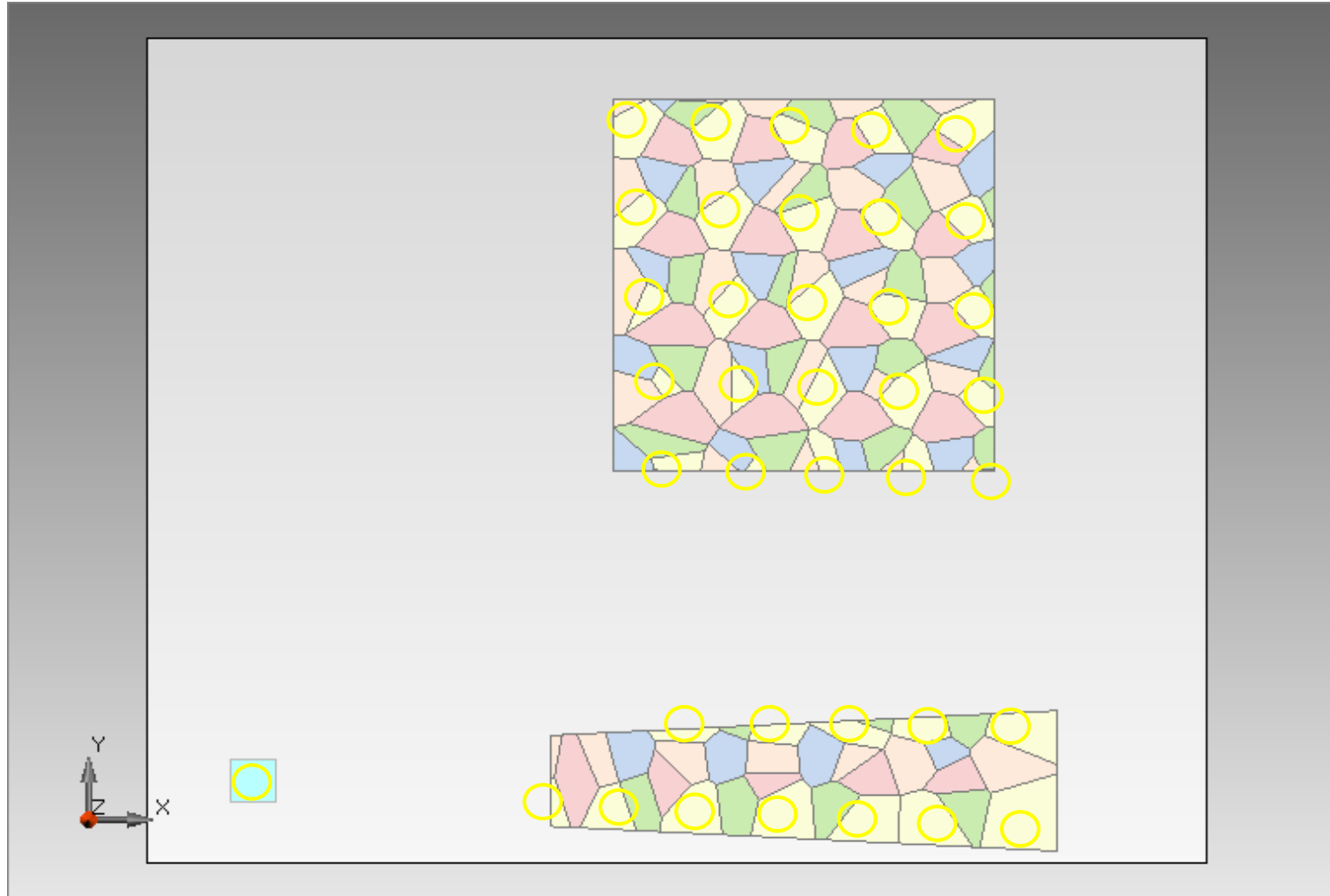

Result Combination of Modes (Segmentation)

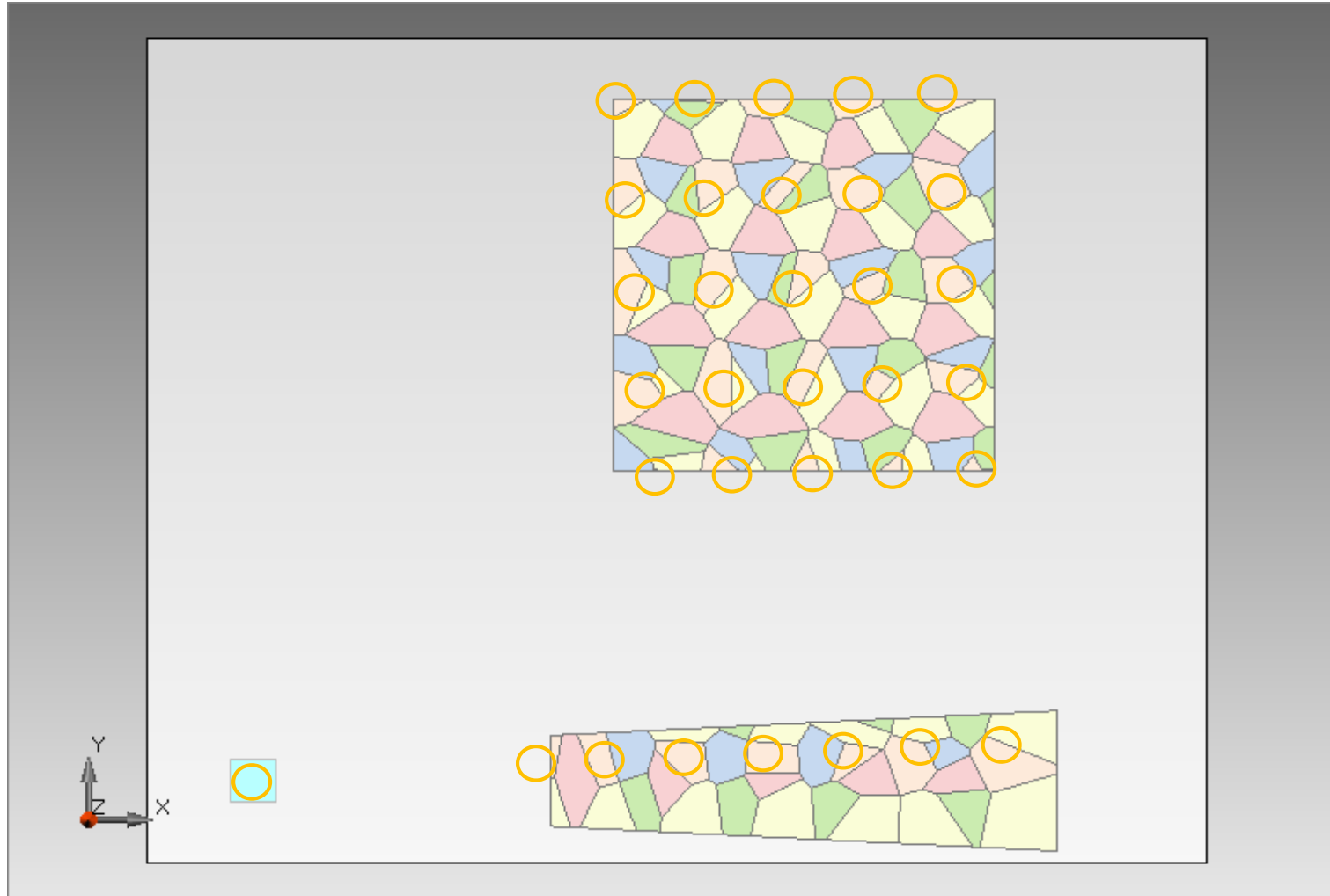

Result Combination of Modes (Segmentation)

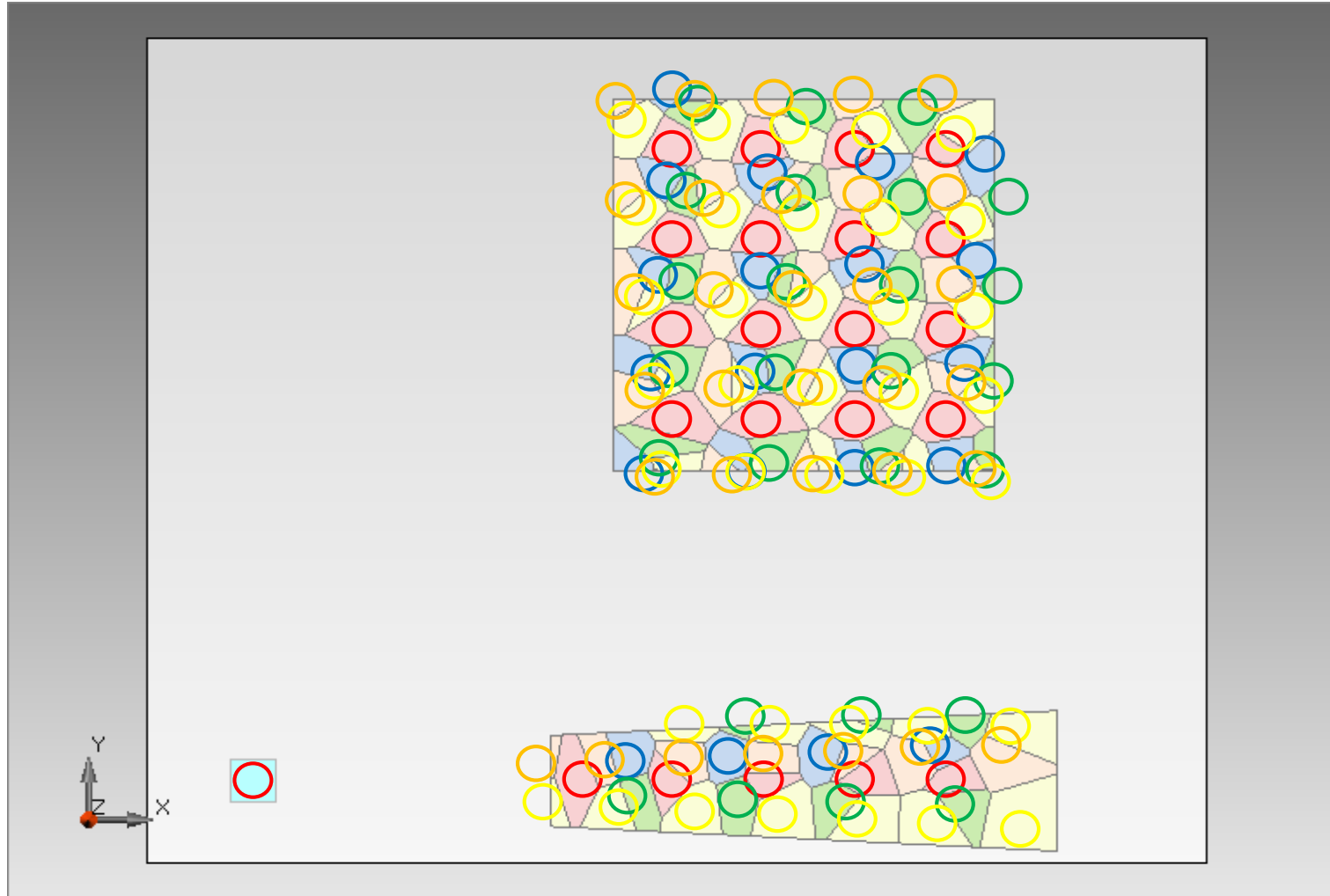

Final Design Results Mode #1 + #2

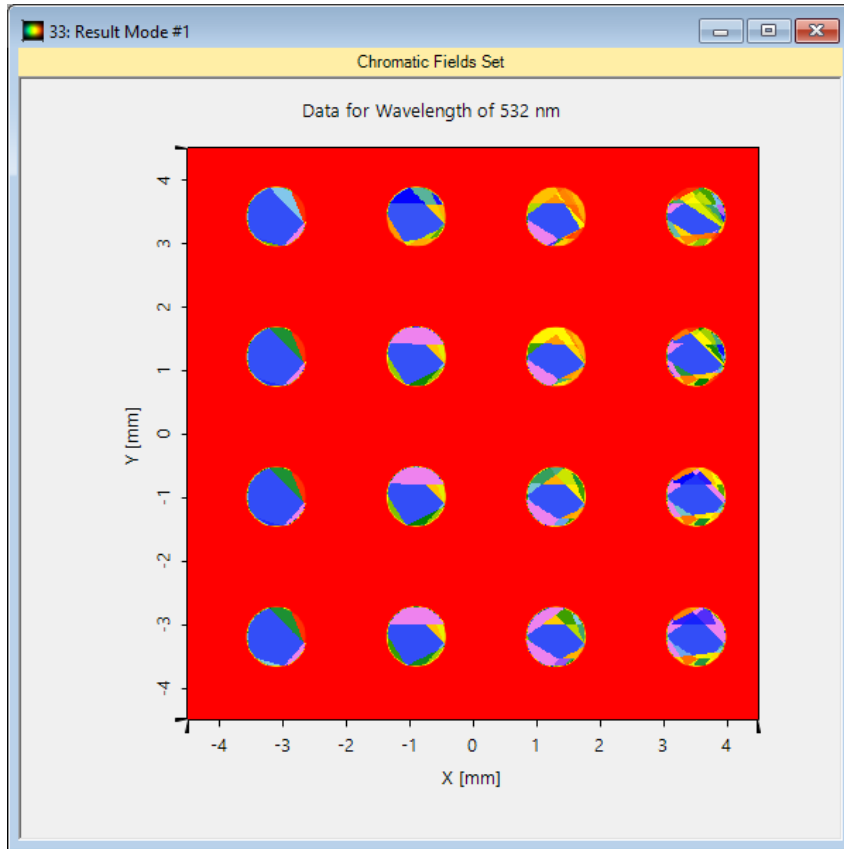

Mode	Merit Function	Value
#1	FOV Angle	$\alpha = 0^\circ; \beta = 0^\circ$
	Uniformity Error	43.90%

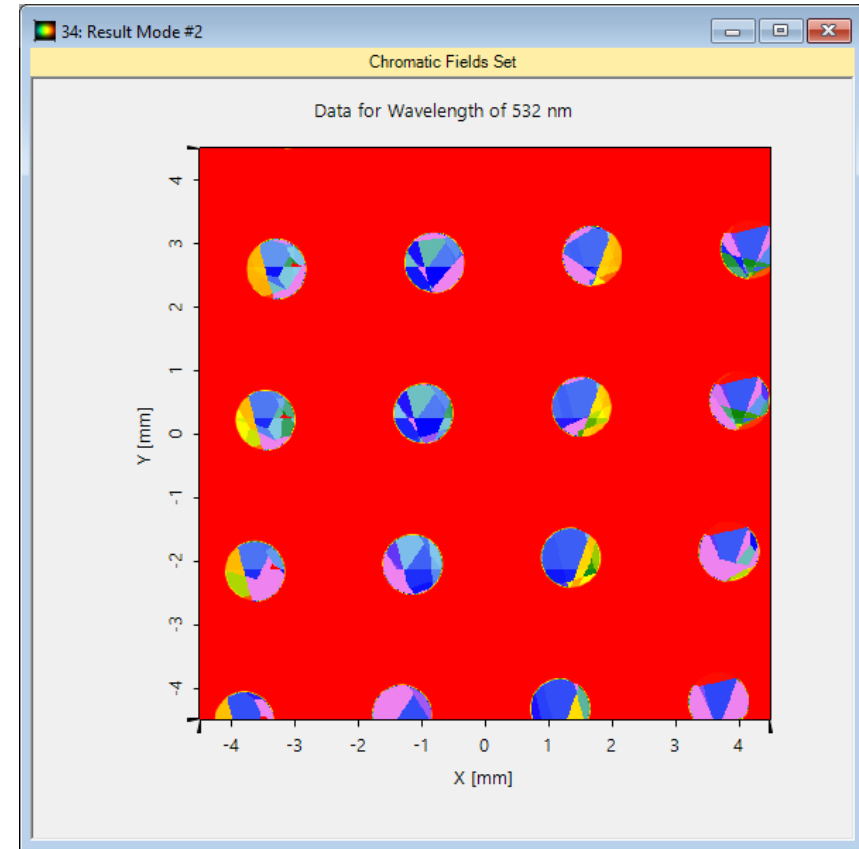

Mode	Merit Function	Value
#2	FOV Angle	$\alpha = 5^\circ; \beta = 3^\circ$
	Uniformity Error	45.61%

Final Design Results Mode #3 - #5

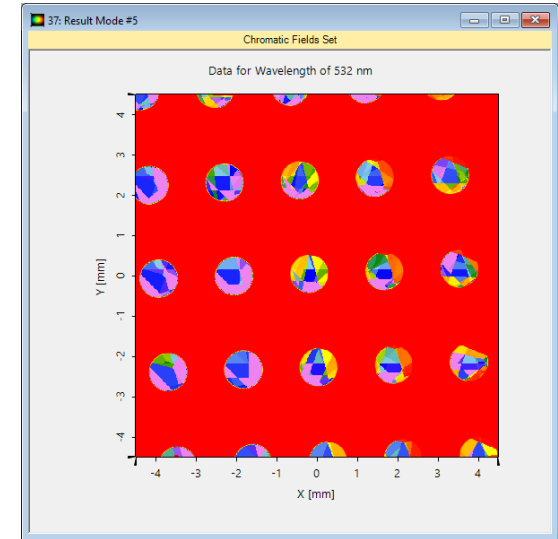
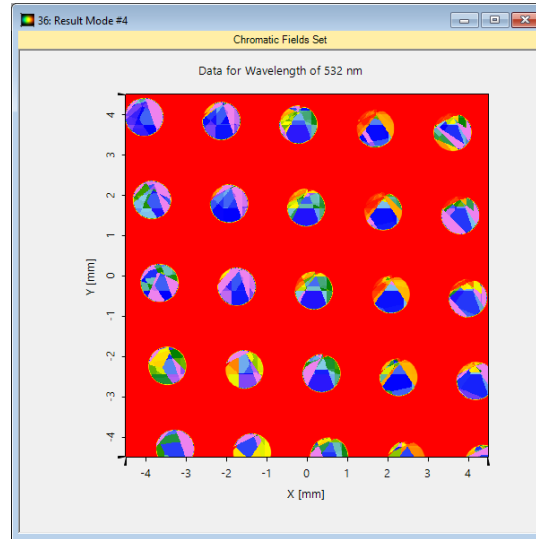
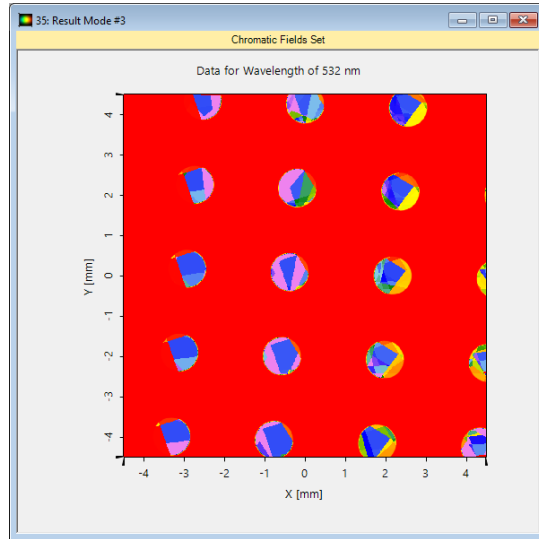

Mode	Merit Function	Value
#3	FOV Angle	$\alpha = 6^\circ; \beta = -2.5^\circ$
	Uniformity Error	39.08%

Mode	Merit Function	Value
#4	FOV Angle	$\alpha = -6^\circ; \beta = -3^\circ$
	Uniformity Error	36.61%

Mode	Merit Function	Value
#5	FOV Angle	$\alpha = -7^\circ; \beta = 2^\circ$
	Uniformity Error	38.01%

Result Combination of Modes (Segmentation)

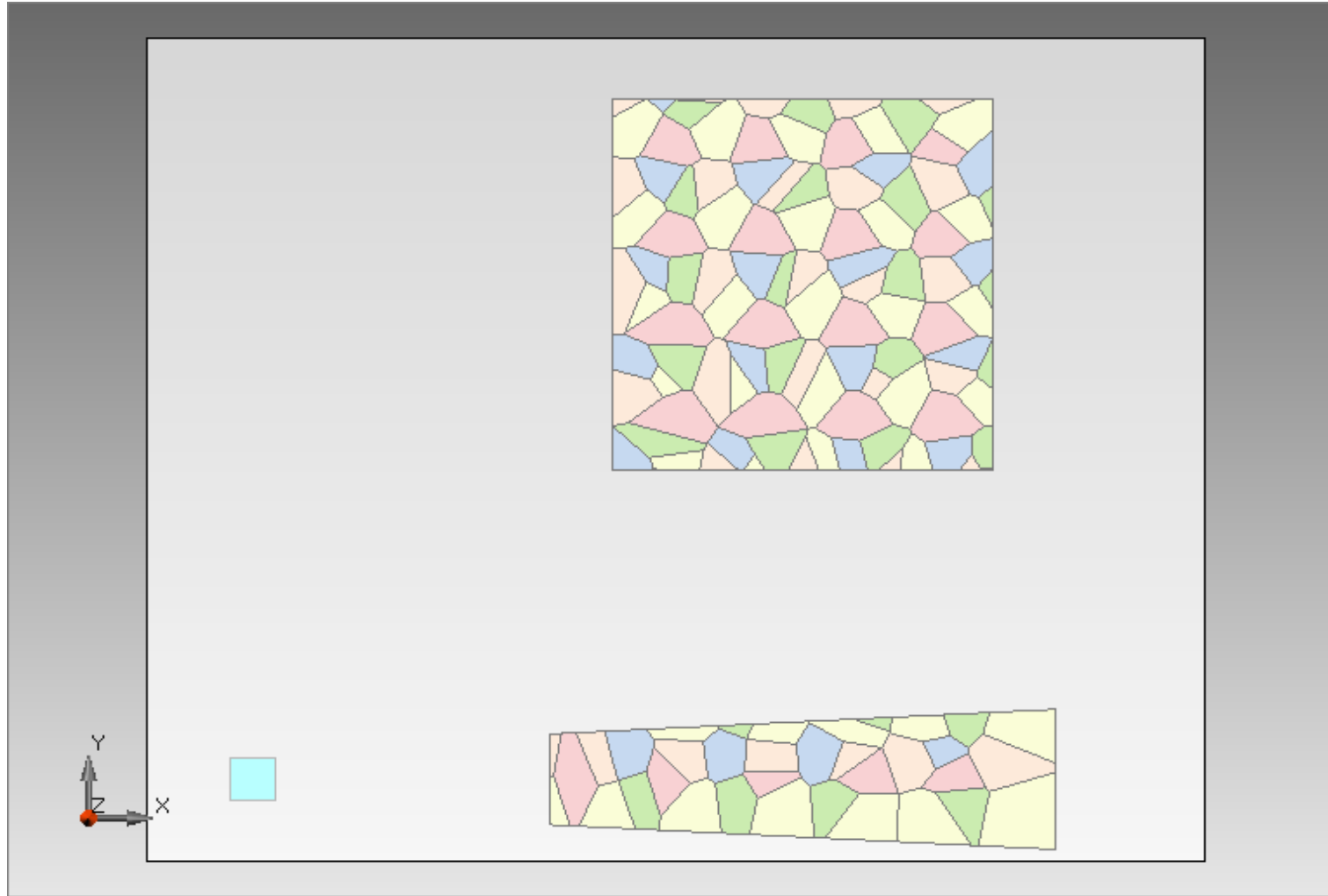

Parametric Optimization and Initial Design

Initial design, e.g.

- Inverse approaches
- Functional design



Parametric optimization

Lightguide Modeling and Design

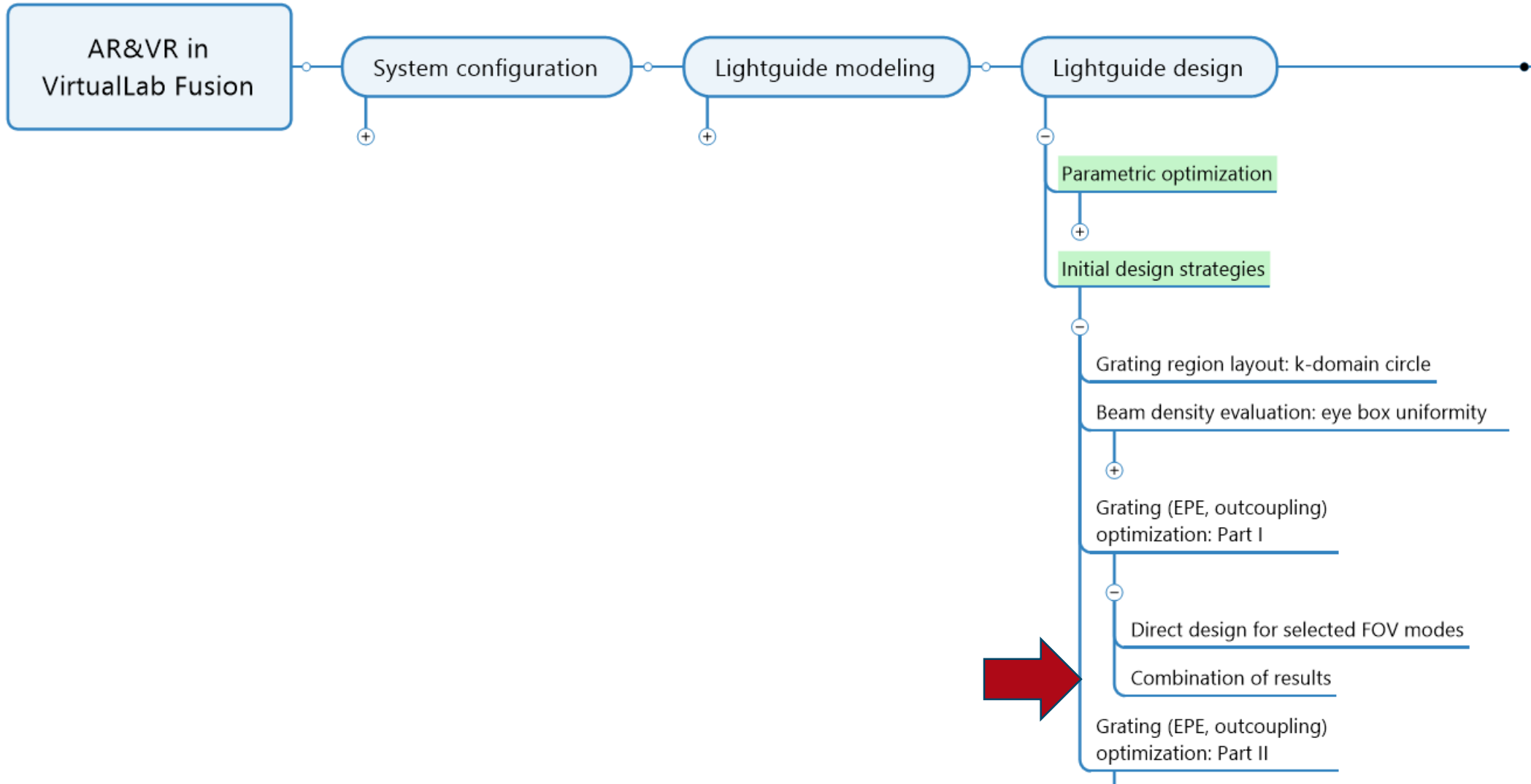

Lightguide Modeling and Design

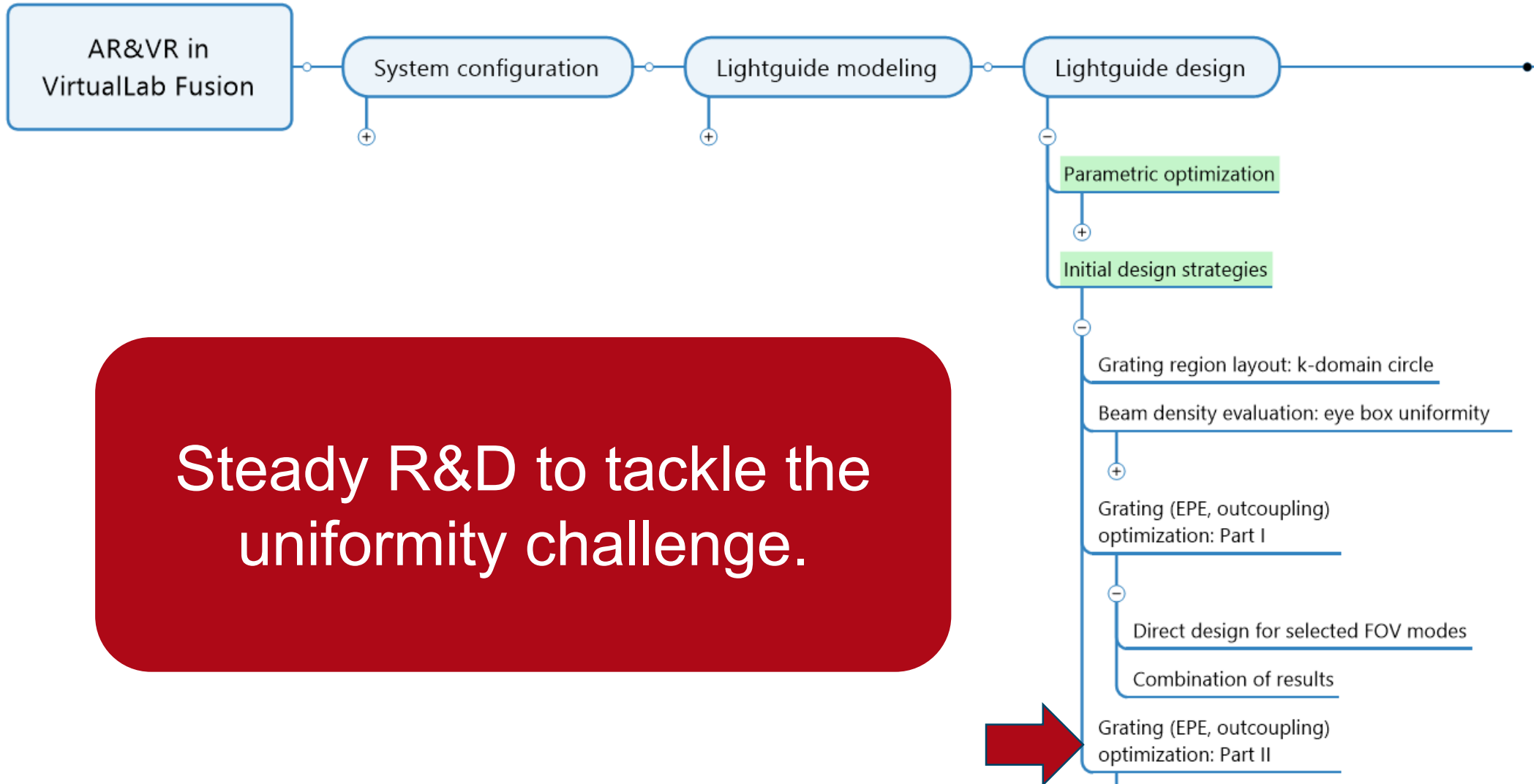

Steady R&D to tackle the uniformity challenge.

Telescope System

FOV modes behave somehow well-sorted

System parameters

Magnification	5.5X
Field of view	4°

$$F/\# = f'/D'$$

where, D 'is the diameter of the entrance pupil

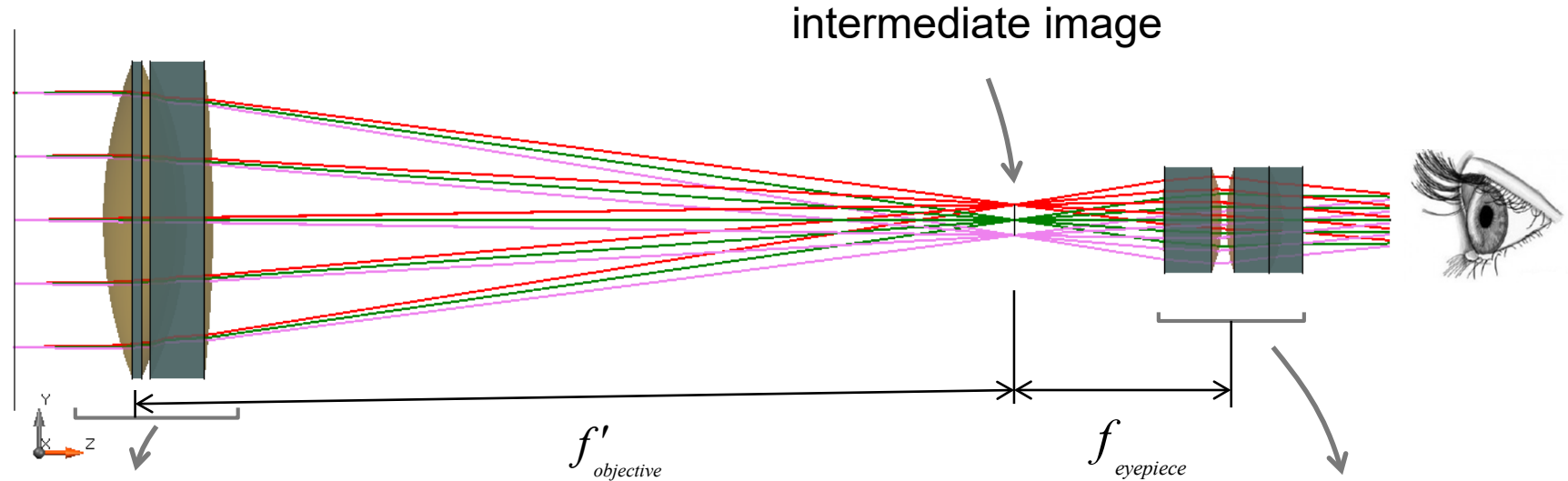

Objective group

Focal length $f'_{objective}$	100 mm
F/#	2.8
number of lenses	4

Eyepiece group

Focal length $f_{eyepiece}$	18.3 mm
Exit Pupil Diameter	3.6 mm
number of lenses	5

Lens source: A_019 and C_001 in Zabase

Design for Multiple FOV Modes: Waveguide

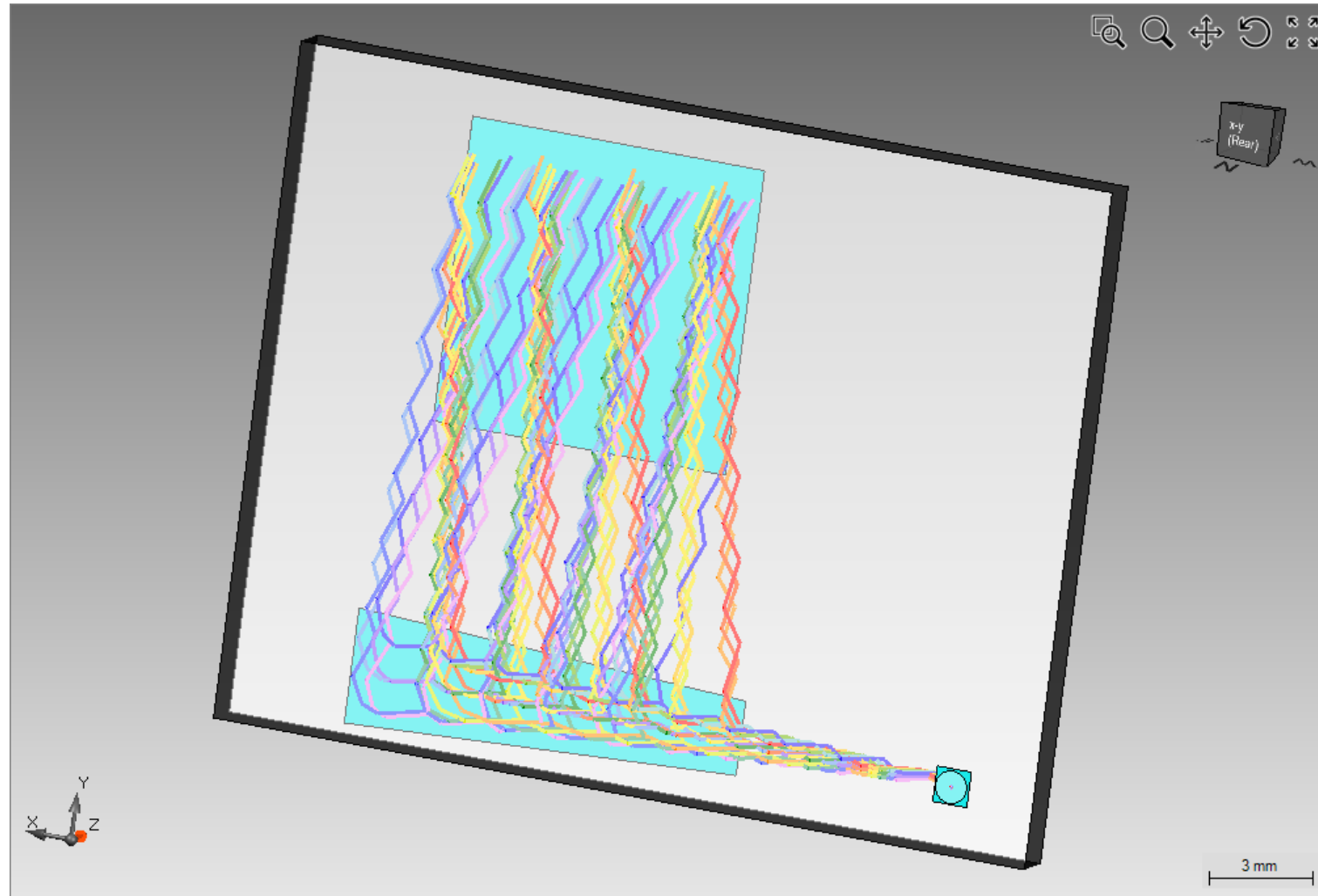

Design for Multiple FOV Modes: Waveguide

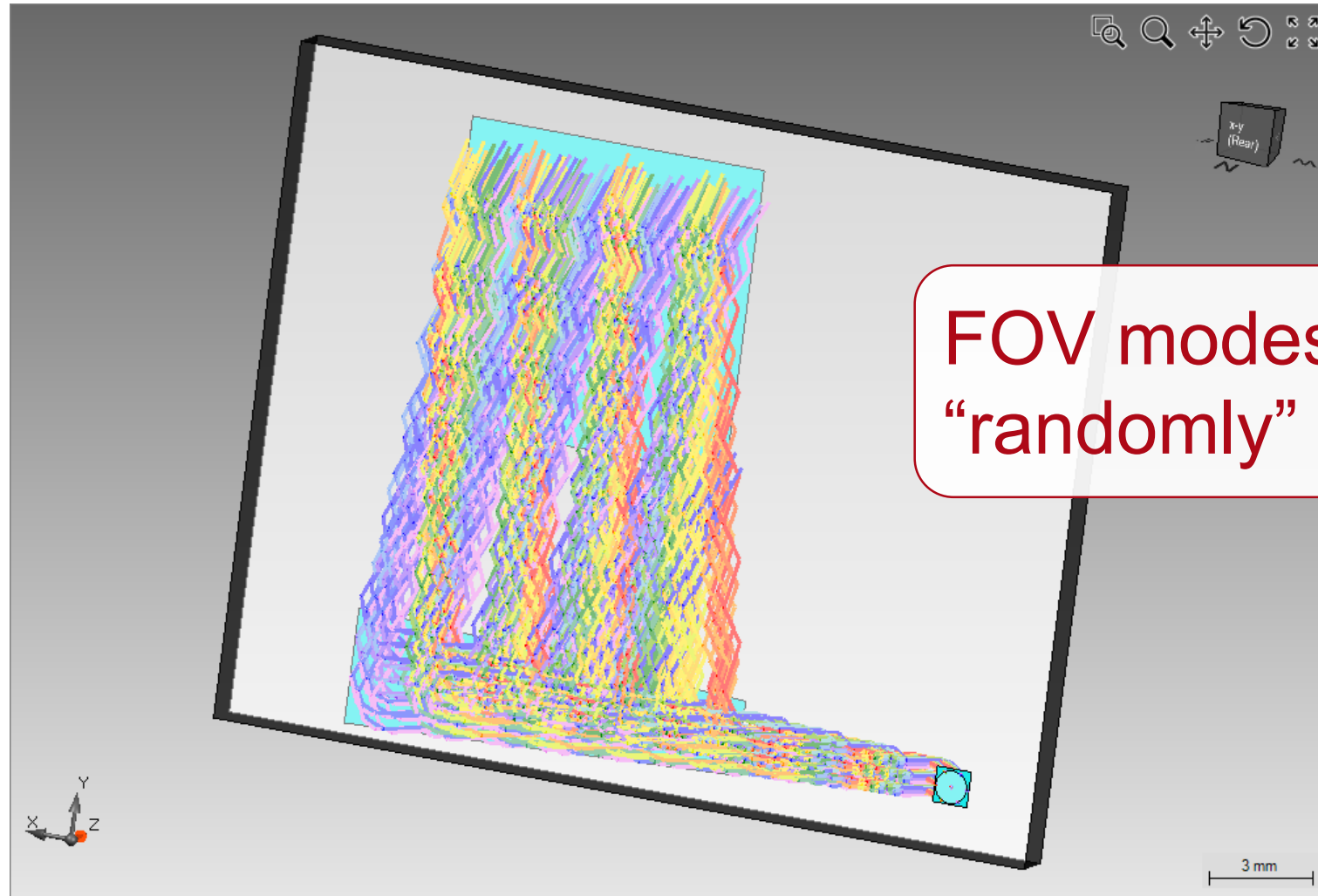

FOV modes laterally
“randomly” mixed up

Parametric Optimization and Initial Design

Initial design, e.g.

- Inverse approaches
- Functional design



Parametric optimization

Thank You!